

# CO5BOLD User Manual

Bernd Freytag

Matthias Steffen

Sven Wedemeyer

Hans-Günter Ludwig

November 20, 2003

## Contents

<b>1</b>	<b>Introduction</b>	<b>5</b>
<b>2</b>	<b>Basic Equations</b>	<b>6</b>
<b>3</b>	<b>Program Files, Installation, Compilation</b>	<b>7</b>
3.1	Quickstart: How to Compile CO5BOLD . . . . .	7
3.2	Compilation Procedure for CO5BOLD . . . . .	7
3.3	Directory Structure . . . . .	10
3.4	Old Setup File for Paths . . . . .	10
3.5	Fortran Files . . . . .	14
3.6	Configure Script . . . . .	17
3.7	Compiler Macros . . . . .	18
3.8	Optimization, Compiler Switches . . . . .	26
3.8.1	Cray: SV1 . . . . .	27
3.8.2	Compaq: alpha . . . . .	27
3.8.3	Hewlett-Packard: V2500 . . . . .	27
3.8.4	Hewlett-Packard: Itanium 2 . . . . .	28
3.8.5	Hitachi SR8000 . . . . .	29
3.8.6	Linux: PGI Compiler . . . . .	31
3.8.7	Linux: Intel Compiler . . . . .	32
3.8.8	NEC SX-5 . . . . .	33
3.8.9	SGI: Origin . . . . .	33
3.8.10	SGI: Origin 2000/3800 at UKAFF . . . . .	34
3.8.11	Sun: SunFire . . . . .	34
<b>4</b>	<b>UIO Data Format</b>	<b>37</b>
4.1	Quickstart: Introduction to UIO . . . . .	37
4.2	Example of UIO Data File . . . . .	37
4.3	Structure of UIO Files . . . . .	38
4.3.1	Data Representation: ASCII or Binary . . . . .	38
4.3.2	Data File Structure . . . . .	39
4.3.3	Tables . . . . .	40
4.3.4	Recommendations for Standard File Structure . . . . .	41
4.4	Files & Directories & Paths . . . . .	42
4.5	Fortran90 . . . . .	42
4.5.1	Files . . . . .	42
4.5.2	Use of UIO Modules in Fortran90 . . . . .	44
4.5.3	Compiling and Makefiles . . . . .	44
4.5.4	Sample Calls of Fortran UIO Routines . . . . .	45
4.6	UNIX Scripts . . . . .	46
4.6.1	Quick Examination of Files: uiolook . . . . .	46
4.6.2	Transformation of Files: uiocat . . . . .	47
4.6.3	Information about Conversion Types: uioinfo . . . . .	47
4.7	IDL UIO Routines . . . . .	48
4.7.1	Initialization of UIO Routines under IDL . . . . .	49
4.7.2	Reading Data with uio_data.pro . . . . .	50
4.7.3	Reading Data with uio_dataset_rd.pro or uio_datasetlist_rd.pro . . . . .	50
<b>5</b>	<b>Control and Data Files</b>	<b>52</b>
5.1	Model Files: rhd.sta, rhd.end, rhd.full . . . . .	52
5.2	File with Additional Data: rhd.mean . . . . .	53
5.2.1	Organization of rhd.mean File . . . . .	53
5.2.2	Contents of Individual rhd.mean File Entry . . . . .	54

5.3	Parameter File: rhd.par . . . . .	57
5.3.1	Quickstart: How to Make a Proper Parameter File . . . . .	58
5.3.2	Header . . . . .	58
5.3.3	Fundamental Model Parameters . . . . .	59
5.3.4	Boundary Conditions . . . . .	61
5.3.5	Equation of State . . . . .	64
5.3.6	Opacities . . . . .	64
5.3.7	Hydrodynamics Control . . . . .	65
5.3.8	Tensor Viscosity Control . . . . .	67
5.3.9	Dust/Molecules . . . . .	69
5.3.10	Radiation Transport Control . . . . .	70
5.3.11	Process Time Management . . . . .	75
5.3.12	Time Step Control . . . . .	76
5.3.13	Input/Output Control . . . . .	79
5.3.14	Additional Information, Obsolete and Test Parameters . . . . .	82
5.4	Additional Control and Status Files: rhd.stop, rhd.cont, and rhd.done . . . . .	85
5.5	Text Output: rhd.out . . . . .	85
<b>6</b>	<b>Running a Simulation</b>	<b>89</b>
6.1	Quickstart: How to Run CO5BOLD . . . . .	89
6.2	Running CO5BOLD on a Machine with Batch System . . . . .	90
<b>7</b>	<b>Data Analysis with IDL</b>	<b>94</b>
7.1	Preparations . . . . .	94
7.2	CO5BOLD Data in IDL . . . . .	94
7.2.1	Loading the Parameter File . . . . .	94
7.2.2	Loading CO5BOLD Data (.full, .sta, .end) . . . . .	94
7.2.3	Loading the Equation of State . . . . .	95
7.2.4	Loading the Opacity Table . . . . .	95
7.2.5	Computation of Deduced Quantities . . . . .	95
7.3	IDL Data Structure . . . . .	95
7.4	More IDL routines . . . . .	97
<b>8</b>	<b>Glossary</b>	<b>98</b>

## List of Figures

1	Old directory scheme . . . . .	11
2	Performance tests on Hitachi SR8000 . . . . .	30
3	Program scheme . . . . .	90

## List of Tables

1	List of source directories . . . . .	10
2	List of old source directories . . . . .	12
3	List of all modules . . . . .	15
4	List of all old modules . . . . .	16
5	UIO conversion types . . . . .	39
6	UIO entry types . . . . .	39
7	UIO header keywords . . . . .	40
8	UIO Fortran90 files . . . . .	43
9	Contents of uio_base_module.f90 . . . . .	43
10	Contents of uio_mac_module . . . . .	44
11	CO5BOLD control and data files . . . . .	52
12	Radiation transport parameters . . . . .	70

# 1 Introduction

CO5BOLD – nickname COBOLD – is the short form of “COnservative COde for the COmputation of COmpressible COnvection in a BOx of L Dimensions with l=2,3”.

It is used to model solar and stellar surface convection. For solar-type stars only a small fraction of the stellar surface layers are included in the computational domain. In the case of red supergiants the computational box contains the entire star.

CO5BOLD solves the coupled non-linear equations of compressible hydrodynamics in an external gravity field together with non-local frequency-dependent radiation transport. Operator splitting is applied to solve the equations of hydrodynamics (including gravity), the radiative energy transfer (with a long-characteristics or a short-characteristics ray scheme), and possibly additional 3D (turbulent) diffusion in individual sub steps. The 3D hydrodynamics step is further simplified with directional splitting. The 1D sub steps are performed with a Roe solver, accounting for an external gravity field and an arbitrary equation of state from a table.

The radiation transport is computed with either one of three modules:

- **MSrad** module: It uses long characteristics. The lateral boundaries have to be periodic. Top and bottom can be closed or open (“solar module”).
- **LHDrad** module: It uses long characteristics and is restricted to an equidistant grid and open boundaries at all surfaces (old “supergiant module”).
- **SHORTrad** module: It uses short characteristics and is restricted to an equidistant grid and open boundaries at all surfaces (new “supergiant module”).

There are preliminary versions of modules for the formation and advection of dust and the transport of magnetic fields available.

CO5BOLD is written in Fortran90. The parallelization is done with OpenMP directives.

To get a brief overview you might want to look into the “Quickstart Sections” “How to Compile CO5BOLD” (Sect. 3.1), “Introduction to UIO” (Sect. 4.1), “How to Make a Proper Parameter File” (Sect. 5.3.1), “How to Run CO5BOLD” (Sect. 6.1).

## 2 Basic Equations

The 3D hydrodynamics equations, including source terms due to gravity, are the mass conservation equation

$$\frac{\partial \rho}{\partial t} + \frac{\partial \rho v_1}{\partial x_1} + \frac{\partial \rho v_2}{\partial x_2} + \frac{\partial \rho v_3}{\partial x_3} = 0 , \quad (1)$$

the momentum equation

$$\frac{\partial}{\partial t} \begin{pmatrix} \rho v_1 \\ \rho v_2 \\ \rho v_3 \end{pmatrix} + \frac{\partial}{\partial x_1} \begin{pmatrix} \rho v_1 v_1 + P \\ \rho v_2 v_1 \\ \rho v_3 v_1 \end{pmatrix} + \frac{\partial}{\partial x_2} \begin{pmatrix} \rho v_1 v_2 \\ \rho v_2 v_2 + P \\ \rho v_3 v_2 \end{pmatrix} + \frac{\partial}{\partial x_3} \begin{pmatrix} \rho v_1 v_3 \\ \rho v_2 v_3 \\ \rho v_3 v_3 + P \end{pmatrix} = \begin{pmatrix} \rho g_1 \\ \rho g_2 \\ \rho g_3 \end{pmatrix} \quad (2)$$

and the energy equation

$$\frac{\partial \rho e_{ik}}{\partial t} + \frac{\partial (\rho e_{ik} + P) v_1}{\partial x_1} + \frac{\partial (\rho e_{ik} + P) v_2}{\partial x_2} + \frac{\partial (\rho e_{ik} + P) v_3}{\partial x_3} = \rho (g_1 v_1 + g_2 v_2 + g_3 v_3). \quad (3)$$

In addition, there are equations for the 3D tensor viscosity and the non-local radiation transport.

### 3 Program Files, Installation, Compilation

In this section all the files and modules CO5BOLD contains are listed. The installation procedure is outlined and compiler switches necessary to compile CO5BOLD and to optimize its performance are described.

#### 3.1 Quickstart: How to Compile CO5BOLD

If you are going to install CO5BOLD on a machine with a “known” (to setup script and makefile) operating system and compiler (see Sections 3.6 and 3.8) then the procedure should be fairly easy. The general compilation procedure is now:

If a directory for the current machine exists (in the tar ball) and the configure script is there:

```
tar -zxvf for.tar.gz
cd for/hd/rhd/YOUR_MACHINE
./configure
make
```

If the directory for the current machine has to be created:

```
tar -zxvf for.tar.gz
cd for/hd/rhd
mkdir YOUR_MACHINE
cd YOUR_MACHINE
ln -s ../conf/configure .
./configure
make
```

The compilation process is explained in more detail in Sect. 3.2. The configure script is described in its header and in Sect. 3.6. The directory structure is shown in Tab. 1. All Fortran files are listed in Tab. 3.

#### 3.2 Compilation Procedure for CO5BOLD

The installation procedure has changed significantly since the last release: now, there is a configure script (see Sect. 3.6) that creates the complete (temporary) makefile which can be used to compile CO5BOLD and produce the executable `rhd.exe`.

Installation procedure:

1. Choose/create a proper base directory. (This will usually be `$HOME`. Then the master directory will typically be `$HOME/for` – this is the default created by the tar file. Some prefer to rename it to `$HOME/HYDRO`.)
2. Put all source files and the configure script there. This will be done typically by expanding the gzipped tar file `for.tar.gz` e.g. with

```
tar -zxvf for.tar.gz
```

(or by copying all files from an existing installation). On a restricted Unix you might be forced to use

```
gunzip for.tar.gz
tar -xvf for.tar
```

instead. Unpacking the tar file creates a sub directory `for` in the local directory (and possible overwrites existing files!). You get sub sub directories as described in Sect. 3.3 and files as listed in Tab. 3. See the Readme file `'for/README'`.

3. Change with

```
cd for/hd/rhd
```

into the main directory.

4. Look at the existing sub directories, e.g. with

```
ls -og | grep "^d"
```

to see if you find one that fits your machine. The directory

```
for/hd/rhd/conf
```

should not be used. It contains only the configure script. But any other directory will do. If you don't like any of the existing directories create your own e.g. with

```
mkdir YOUR_MACHINE
```

Change into this directory with

```
cd YOUR_MACHINE
```

5. Check if there is a configure script or a link to it with

```
ls -og configure
```

which should give something like

```
lrwxrwxrwx  1  17 2002-12-04 17:39 configure -> ../conf/configure
```

If it is not there, create the link with

```
ln -s ../conf/configure .
```

6. Start the configure script to create the (first version of the) Makefile

```
./configure
```

This gives you a screen output like

```
Configuration script for C05BOLD Makefile
```

```
=====
```

```
No parallelization requested, assume default: F90_PARALLEL=scalar
No debugging requested, assume default:      F90_DEBUG=0
No LHDrad  module requested, assume default:  F90_LHDRAD=0
No MSrad   module requested, assume default:  F90_MS RAD=0
No SHORTrad module requested, assume default: F90_SHORTRAD=1
No dust    module requested, assume default:  F90_DUST=0
No MHD     module requested, assume default:  F90_MHD=0
No explicit machine requested, assume default: F90_MACHINE=local
```

```
List of control environment variables:
```

```
F90_COMPILER =
```



```

F90_PREFLAGS =
F90_POSTFLAGS=
F90_PARALLEL = scalar
F90_DEBUG     = 0
F90_LHDRAD   = 0
F90_MS RAD   = 0
F90_SHORTRAD = 1
F90_DUST     = 0
F90_MHD      = 0
F90_MACHINE  = local
-> MACHINE    = i686
F90_BASEPATH = /home/bf/for

```

Linux system with i686 architecture

```

PGI compiler
version=3.3-2

```

```
pgf90 -byteswapio -fast -Mvect=sse -Mcache_align -Minfo=inline
```

Write compiler name and flags into file `compiler_flags.info`

Makefile already exists. It is appended to `Makefile_old`.

New Makefile written.....

A new 'Makefile' is produced. An existing one is appended to 'Makefile\_old'. Additionally, the file 'compiler\_flags.info' is written which contains the compiler call in Fortran format.

7. Check the output of the configure script and the header of the new Makefile. You get an overview over the relevant environment variables that control the configure script (see Sect. 3.6) with

```
env | grep F90_
```

Obs: at the beginning there might be none.

8. Look into the header (and if necessary the rest) of the configure script or into Sect. 3.6 to find out how to change the environment variables to control the script properly. For instance, if you want to enable debugging options, type:

```
export F90_DEBUG=1
```

Restart the configure script after every change in the control variables!

9. Start the compilation with

```
make
```

to produce the executable `rh.d.exe`.

A simple sample installation may look like the following (the sub directory 'for' is put into the home directory).

```

# --- Choose base directory ---
cd $HOME

```

```

# --- Put the tar file there ---
# ...

# --- Expand the tar file ---
tar -zxvf for.tar.gz

# --- Go into (default) master directory ---
cd for/hd/rhd/YOUR_MACHINE

# --- Activate OpenMP und MSrad radiation transport ---
export F90_PARALLEL=openmp
export F90_MSRAD=1

# --- Start the configure script ---
./configure

# --- Compile ---
make

echo 'Voila!'

```

### 3.3 Directory Structure

The files necessary to compile CO5BOLD are distributed over a few directories. A typical setup would be to put everything into the main directory `for`. Then the source files would be located as in Tab. 1.

Paths	Abb.	Description
<code>\${HOME}/for/con/f90/</code>	CON	constants and units
<code>\${HOME}/for/dust/f90/</code>	DUST	source terms due to dust or molecules
<code>\${HOME}/for/eos/f90/</code>	EOS	equation of state
<code>\${HOME}/for/hd/mhd/</code>	MHD	MHD routines
<code>\${HOME}/for/hd/rhd/</code>	RHD	main rhd routines (hydro, Bernd's radiation transport)
<code>\${HOME}/for/hd/rhdb/</code>	RHDB	basic rhd routines
<code>\${HOME}/for/mat/str/</code>	STR	string handling
<code>\${HOME}/for/opa/opta/</code>	OPTA	opacities
<code>\${HOME}/for/rad/hdrad/</code>	RAD	Matthias' radiation transport
<code>\${HOME}/for/uio/f90/</code>	UIO	I/O routines
<code>\${HOME}/for/time/f90/</code>	TIME	timing routines

Table 1: List of source directories with path and file name, abbreviation, and a short description.

The executables (and makefiles, object files, module information files) are usually located in subdirectories of the source code directories. These subdirectories typically have the name of the machine, architecture, or operating system the executable is compiled for.

The former directory organization can be found in Tab. 2 and Fig. 1.

### 3.4 Old Setup File for Paths

For the previous version of CO5BOLD all paths were stored in environment variables and could be set with the scripts

```
setarcdeppaths.sh
```

or

```
setarcdeppaths.csh
setarcdeppaths.sh
```

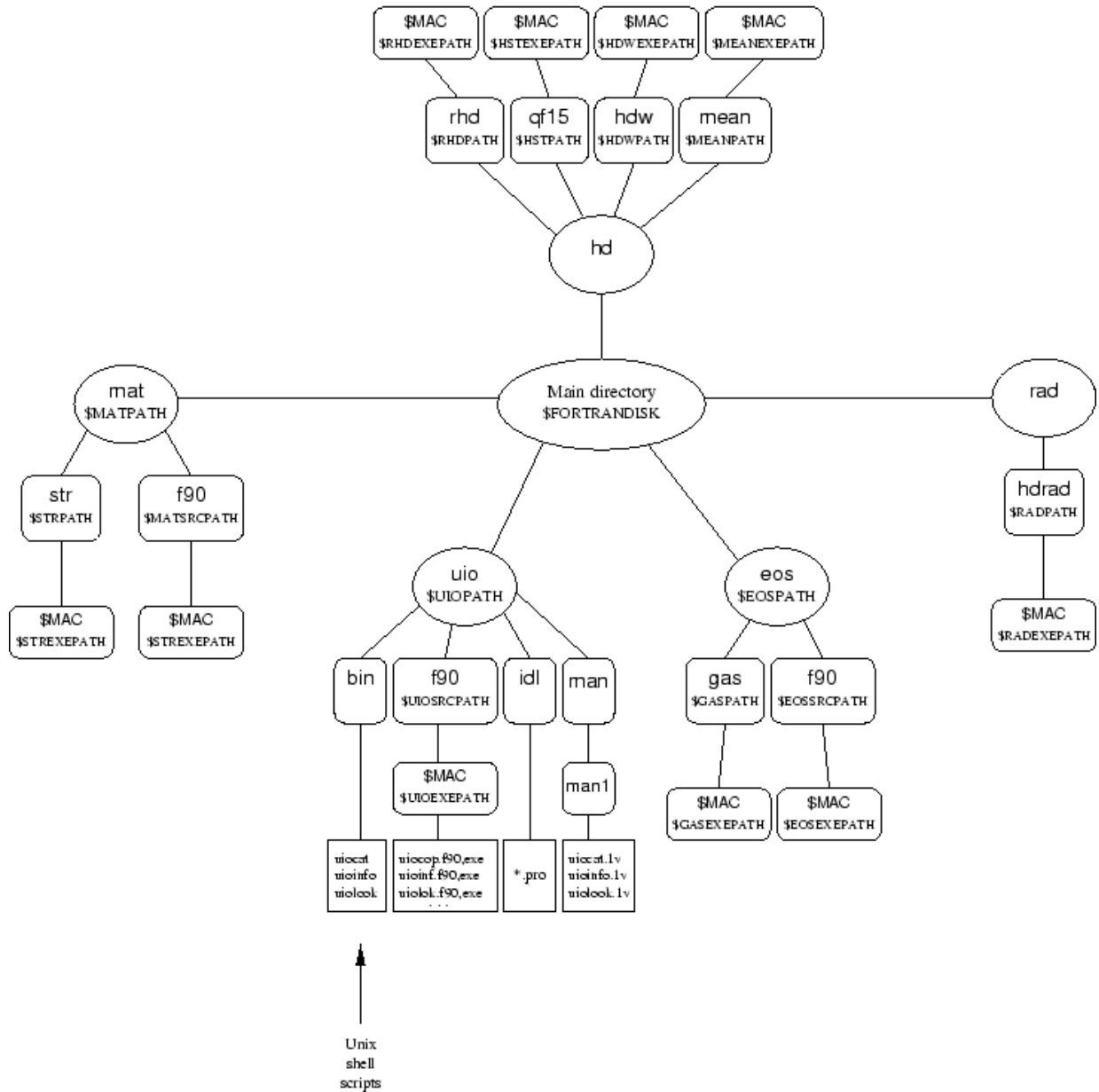

Figure 1: Old directory scheme

Paths	Abb.	Description
<code>\${HOME}/for/mat/str/</code>	STR	string handling
<code>\${HOME}/for/uio/f90/</code>	UIO	I/O routines
<code>\${HOME}/for/eos/f90/</code>	EOS	equation of state
<code>\${HOME}/for/rad/hdrad/</code>	RAD	opacities, Matthias' radiation transport
<code>\${HOME}/for/hd/rhd/</code>	RHD	main rhd routines

Table 2: For historical reasons: list of old source directories with path and file name, abbreviation, and a short description.

```
setarcdeppaths.csh .
```

These variables are now *ignored* by the configure script that produces the Makefile to generate the CO5BOLD executable `rhd.exe`.

However, they are still used e.g. by the makefile that produces the executables that are called by the UIO scripts. The environment variables for the UIO routines can be e.g.

```
UIOSRCPATH=/home/user/for/uio/f90
UIOEXEPATH=/home/user/for/uio/f90/sun .
```

A script to set all necessary variables and paths can be (here for the Bourne shell)

```
#!/bin/sh
#
# --- Disk where all Fortran programs are located ---
FORTRANDISK=$HOME/for ; export FORTRANDISK
#
if [ 'uname -s' = "craSH" ]; then
  # --- Kiel: craSHi ---
  #
  UIOMAC=uiio_mac_crayxmp_module ; export UIOMAC
  RHDMAC=rhd_mac_cray_module ; export RHDMAC
elif [ 'uname -s' = "craSH" ]; then
  # --- Kiel: craSH ---
  #
  UIOMAC=uiio_mac_crayts_module ; export UIOMAC
  RHDMAC=rhd_mac_cray_module ; export RHDMAC
elif [ 'uname -m' = "SR8000" ]; then
  # --- Potsdam: Hitachi ---
  #
  UIOMAC=uiio_mac_hitachi_module ; export UIOMAC
  RHDMAC=rhd_mac_hitachi_module ; export RHDMAC
else
  # --- Default: Suns MAC files ---
  #
  UIOMAC=uiio_mac_sun_module; export UIOMAC
  RHDMAC=rhd_mac_sun_module; export RHDMAC
fi
#
# --- Architecture dependent sub directory names for object file and executables ---
if [ 'uname -s' = "craSH" ]; then
  MAC=crash
elif [ 'uname -s' = "craSHi" ]; then
  MAC=crashi
elif [ 'uname -s' = "SunOS" ]; then
  MAC=sun
elif [ 'uname -s' = "HP-UX" ]; then
  if [ 'uname -m' = "ia64" ]; then
    MAC=hpia64
```

```

else
  MAC=hp
fi
elif [ 'uname -s' = "Linux" ]; then
  MAC=linux
elif [ 'uname -n' = "vx1" ]; then
  MAC=vx1
else
  MAC=sgi
fi
#
# --- Individual libraries ---
# --- Timing ---
TIMEPATH=$FORTRANDISK/time/f90 ; export TIMEPATH
TIMESRCPATH=$TIMEPATH ; export TIMESRCPATH
#
# --- Constants & units ---
CONPATH=$FORTRANDISK/con/f90 ; export CONPATH
CONSRCPATH=$CONPATH ; export CONSRCPATH
#
# --- uio ---
UIOPATH=$FORTRANDISK/uio ; export UIOPATH
UIOSRCPATH=$UIOPATH/f90 ; export UIOSRCPATH
#
# --- String handling ---
STRPATH=$FORTRANDISK/mat/str ; export STRPATH
STRSRCPATH=$STRPATH ; export STRSRCPATH
#
# --- Math ---
MATPATH=$FORTRANDISK/mat ; export MATPATH
MATSRCPATH=$MATPATH/f90 ; export MATSRCPATH
#
# --- gas ---
GASPATH=$FORTRANDISK/eos/gas ; export GASPATH
GASSRCPATH=$GASPATH ; export GASSRCPATH
#
# --- EOS ---
EOSPATH=$FORTRANDISK/eos ; export EOSPATH
EOSSRCPATH=$EOSPATH/f90 ; export EOSSRCPATH
#
# --- Opacity ---
OPTAPATH=$FORTRANDISK/opa/opta ; export OPTAPATH
OPTASRCPATH=$OPTAPATH ; export OPTASRCPATH
#
# --- hydrostatic ---
HSTPATH=$FORTRANDISK/hd/qf15 ; export HSTPATH
HSTSRCPTH=$HSTPATH ; export HSTSRCPTH
#
# --- rad ---
RADPATH=$FORTRANDISK/rad/hdrad ; export RADPATH
RADSRCPTH=$RADPATH ; export RADSRCPTH
#
# --- RHD ---
RHDPATH=$FORTRANDISK/hd/rhd ; export RHDPATH
RHDSRCPTH=$RHDPATH ; export RHDSRCPTH
#
# --- RHDB ---
RHDBPATH=$FORTRANDISK/hd/rhdb ; export RHDBPATH
RHDBSRCPATH=$RHDBPATH ; export RHDBSRCPATH
#
# --- HDW ---

```

```

HDWPATH=$FORTRANDISK/hd/hdw ; export HDWPATH
HDWSRCPATH=$HDWPATH ; export HDWSRCPATH
#
# --- DUST ---
DUSTPATH=$FORTRANDISK/hd/dust ; export DUSTPATH
DUSTSRCPATH=$DUSTPATH ; export DUSTSRCPATH
#
# --- MHD ---
MHDPATH=$FORTRANDISK/hd/mhd ; export MHDPATH
MHDSRCPATH=$MHDPATH ; export MHDSRCPATH
#
# --- mean ---
MEANPATH=$FORTRANDISK/hd/mean ; export MEANPATH
MEANSRCPATH=$MEANPATH ; export MEANSRCPATH
#
# --- Architecture dependent directories for object file and executables ---
TIMEEXEPATH=$TIMEPATH/$MAC ; export TIMEEXEPATH
CONEXEPATH=$CONPATH/$MAC ; export CONEXEPATH
UIOEXEPATH=$UIOSRCPATH/$MAC ; export UIOEXEPATH
STREXEPATH=$STRPATH/$MAC ; export STREXEPATH
MATEXEPATH=$MATSRCPTH/$MAC ; export MATEXEPATH
GASEXEPATH=$GASPATH/$MAC ; export GASEXEPATH
EOSEXEPATH=$EOSSRCPATH/$MAC ; export EOSEXEPATH
OPTAEXEPATH=$OPTAPATH/$MAC ; export OPTAEXEPATH
HSTEXEPATH=$HSTPATH/$MAC ; export HSTEXEPATH
RADEXEPATH=$RADPATH/$MAC ; export RADEXEPATH
RHDEXEPATH=$RHDPATH/$MAC ; export RHDEXEPATH
RHBEXEPATH=$RHDBPATH/$MAC ; export RHBEXEPATH
HDWEXEPATH=$HDWPATH/$MAC ; export HDWEXEPATH
DUSTEXEPATH=$DUSTPATH/$MAC ; export DUSTEXEPATH
MHDEXEPATH=$MHDPATH/$MAC ; export MHDEXEPATH
MEANEXEPATH=$MEANPATH/$MAC ; export MEANEXEPATH

```

This script can be executed with

```
. $HOME/bin/setarcdeppaths.sh
```

This line can be put e.g. into the `.bashrc` file.

Some lines can be edited to account for individual choices and the target machine. With

```
FORTRANDISK=$HOME/for ; export FORTRANDISK
```

the master directory is specified. With

```
UIOMAC=uiio_mac_sun_module; export UIOMAC
RHDMAC=rhd_mac_sun_module; export RHDMAC
```

you set some machine dependent modules. The `sun` modules work for most machines (e.g. for Linux PCs). With

```
MAC=linux
```

you specify the name of the subdirectories with the makefiles. The other lines only have to be edited if you want to organize the directories in a completely different way. In this case you have to adapt the configure script, too.

### 3.5 Fortran Files

Table 3 shows a list of all source files necessary to compile CO5BOLD. Table 4 shows the former list.

File and path	Abb.	Description
hd/rhd/rhd.F90	RHD	main program
hd/rhd/rhd_hyd_module.F90	RHD	hydrodynamics routines
hd/rhd/rhd_lhdrad_module.F90	RHD	radiative transfer routines, long characteristics, supergiant case
hd/rhd/rhd_shortrad_module.F90	RHD	radiative transfer routines, short characteristics, supergiant case
hd/rhd/rhd_shortrad_dtauop01.f90	RHD	short characteristics tau-coupling
hd/rhd/rhd_shortrad_dtauop02.f90	RHD	short characteristics tau-coupling
hd/rhd/rhd_shortrad_operator00.f90	RHD	short characteristics operator
...		
hd/rhd/rhd_shortrad_operator08.f90	RHD	short characteristics operator
hd/rhd/rhd_vis_module.F90	RHD	tensor viscosity routines
rad/hdrad/rhd_rad_module.f90	RAD	interface for Matthias' radiation routine
rad/hdrad/MSrad3D.F90	RAD	Matthias' radiation transport routines, long characteristics, periodic sides
hd/dust/rhd_dust_module.F90	DUST	dust/molecule formation
hd/dust/dust_k3mon_module.f	DUST	1 or 2 component dust model
hd/mhd/rhd_mhd_module.F90	MHD	magnet fields (first version)
eos/f90/gasinter_routines.f90	EOS	equation of state
opa/opta/cubit_module.f	OPTA	cubic interpolation
opa/opta/opta_par_module.f90	OPTA	parameters for opacity routines
opa/opta/opta_routines.f	OPTA	opacity
hd/rhdb/rhd_action_module.f90	RHDB	routines for control parameter passing
hd/rhdb/rhd_box_module.f90	RHDB	box handling routines
hd/rhdb/rhd_dat_module.f90	RHDB	handling of additional data (averages)
hd/rhdb/rhd_gl_module.f90	RHDB	global parameters
hd/rhdb/rhd_io_module.f90	RHDB	input/output routines
hd/rhdb/rhd_mac_cray_module.f90	RHDB	machine dependent routines (CRAY)
hd/rhdb/rhd_mac_default_module.f90	RHDB	machine dependent routines (default)
hd/rhdb/rhd_mac_hitachi_module.f90	RHDB	machine dependent routines (Hitachi)
hd/rhdb/rhd_mac_sun_module.f90	RHDB	mac-dependent routines (Sun, others)
hd/rhdb/rhd_mean_module.f90	RHDB	averaging routines
hd/rhdb/rhd_prop_module.f90	RHDB	box properties
hd/rhdb/rhd_sub_module.f90	RHDB	additional routines
con/f90/const_module.f90	CON	physical and mathematical constants
mat/str/str_module.f90	STR	string handling
time/f90/timing_module.f90	TIME	timing routines
uio/f90/uio_base_module.f90	UIO	I/O routines
uio/f90/uio_bulk_module.f90	UIO	I/O routines
uio/f90/uio_filedef_module.f90	UIO	I/O routines
uio/f90/uio_mac_crayts_module.f90	UIO	I/O routines, machine dependent part
uio/f90/uio_mac_crayxmp_module.f90	UIO	I/O routines, machine dependent part
uio/f90/uio_mac_decalpha_module.f90	UIO	I/O routines, machine dependent part
uio/f90/uio_mac_hitachi_module.f90	UIO	I/O routines, machine dependent part
uio/f90/uio_mac_ieee_module.f90	UIO	I/O routines, machine dependent part
uio/f90/uio_mac_intel_module.f90	UIO	I/O routines, machine dependent part
uio/f90/uio_mac_module.f90	UIO	I/O routines, m.-d., minimal version
uio/f90/uio_mac_nec_module.f90	UIO	I/O routines, machine dependent part
uio/f90/uio_mac_sun_module.f90	UIO	I/O, m.-d., works in most cases

Table 3: List of all modules: the table shows the file name with part of its path, the shortcut for the directory, and its description.

File and path	Abb.	Description
mat/str/str_module.f90	STR	string handling
uio/f90/uio_base_module.f90	UIO	I/O routines
uio/f90/uio_bulk_module.f90	UIO	I/O routines
uio/f90/uio_filedef_module.f90	UIO	I/O routines
uio/f90/uio_mac_sun_module.f90	UIO	I/O routines, machine dependent part
eos/f90/gasinter_routines.f90	EOS	equation of state
rad/hdrad/cubit_module.f	RAD	cubic interpolation
rad/hdrad/opta_par_module.f90	RAD	parameters for opacity routines
rad/hdrad/opta_routines.f	RAD	opacity
rad/hdrad/MSrad3D.F90	RAD	Matthias' radiation transport routines, long characteristics, periodic sides
hd/rhd/timing_module.f90	RHD	timing routines
hd/rhd/rhd_const_module.f90	RHD	physical and mathematical constants
hd/rhd/rhd_gl_module.f90	RHD	global parameters
hd/rhd/rhd_action_module.f90	RHD	routines for control parameter passing
hd/rhd/rhd_box_module.f90	RHD	box handling routines
hd/rhd/rhd_dat_module.f90	RHD	handling of additional data (averages)
hd/rhd/rhd_mean_module.f90	RHD	averaging routines
hd/rhd/rhd_io_module.f90	RHD	input/output routines
hd/rhd/rhd_mac_cray_module.f90	RHD	machine dependent routines (CRAY)
hd/rhd/rhd_mac_default_module.f90	RHD	machine dependent routines (default)
hd/rhd/rhd_mac_sun_module.f90	RHD	machine dependent routines (Sun)
hd/rhd/rhd_sub_module.f90	RHD	additional routines
hd/rhd/rhd_hyd_module.F90	RHD	hydrodynamics routines
hd/rhd/rhd_vis_module.F90	RHD	tensor viscosity routines
hd/rhd/rhd_rad_module.f90	RHD	interface for Matthias' radiation routine
hd/rhd/rhd_lhdrad_module.F90	RHD	radiative transfer routines, long characteristics, supergiant case
hd/rhd/rhd_shortrad_module.F90	RHD	radiative transfer routines, short characteristics, supergiant case
hd/rhd/rhd.F90	RHD	main program

Table 4: For historical reasons: list of all old modules: the table shows the file name with part of its path, the shortcut for the directory, and its description.



### 3.6 Configure Script

The configure script produces a Makefile.

It is controlled by environment variables (see below). It tries to use reasonable default values if they are not set (properly). In the script the machine type is determined with ‘uname - m’. According to the control variables and the machine architecture the compiler name and its compiler flags are composed. These are written into the header of a Makefile which is produced in the end. An existing Makefile is appended to

`Makefile_old`.

Additionally the compilation command is written into the file

`'compiler_flags.info'`

in a form ready to be included in a Fortran program.

The environment variables that control the script are

- **F90\_COMPILER:**  
Fortran compiler:
  - `''`: a machine dependent default is chosen individually for each architecture
  - `f90`: general default
- **F90\_PREFLAGS:**  
Compiler flags to be put at the beginning of the list. Usually, the list of compiler flags produced by the configure script should be pretty complete. But you might want to add special switches like `'-Bstatic'` to enforce static linking of libraries.
  - `''`: No extra flags
- **F90\_POSTFLAGS:**  
Compiler flags to be put at the end of the list. Usually, the list of compiler flags produced by the configure script should be pretty complete. However, you might want to overwrite some settings. This can be done by setting this variable to a none-empty value because typically a compiler should interpret the flags from left to right.
  - `''`: No extra flags
- **F90\_PARALLEL:**  
Parallelization scheme:
  - `scalar`: no parallelization (default)
  - `openmp`: OpenMP (appropriate for CO5BOLD)
  - `auto`: auto-parallelization (not implemented for all machines)
- **F90\_DEBUG:**  
Debugging level:
  - `0`: No extra debugging information produced, full optimization is chosen (default)
  - `1`: standard debugging mode (typically switch `'-g'` instead of `'-fast'`)
  - `2`: other debugging (or array checking) modes possible if implemented for the requested machine
- **F90\_LHDRAD:**  
LHDrad radiation transport:
  - `0`: do not activate (compile and link) this module (default)
  - `1`: activate this radiation transport module

- **F90\_MSRAD:**  
MSrad radiation transport:
  - 0: do not activate (compile and link) this module (default)
  - 1: activate this radiation transport module
- **F90\_SHORTRAD:**  
SHORTrad radiation transport:
  - 0: do not activate (compile and link) this module (default)
  - 1: activate this radiation transport module
- **F90\_DUST:**  
DUST module:
  - 0: do not activate (compile and link) this module (default)
  - 1: activate this radiation transport module

If this variable is set to 1 the compiler is called with `-Drhd_box_quc01=1`, see Sect. 3.7.

- **F90\_MHD:**  
MHD module:
  - 0: do not activate (compile and link) this module (default)
  - 1: activate this radiation transport module
- **F90\_MACHINE:**  
Explicit machine specification. This is usually not necessary, use 'local' or '' instead.
  - '': local machine
  - `sun4u`: Sun
  - ...: See the header of the configure script for an up to date list
  - `local`: local machine (default)
  - `dummy`: Do not use any machine dependent flags but use module selections
  - `empty`: Compiler flags are composed from `F90_PREFLAGS` and `F90_POSTFLAGS` only
- **F90\_BASEPATH:**  
Path for CO5BOLD base directory.
  - '': The configure script tries to determine the base directory name automatically (default). This should work if the local directory is located somewhere below `.../hd/rhd/`
  - otherwise: This string is used as base directory name (e.g. `/home/user/for`)

Some examples can be found in Sect. 3.2.

### 3.7 Compiler Macros

Some of the modules of the CO5BOLD code (with suffix “.F90”) employ compiler macros to switch between code versions during compile time. Typically you define at least one of the three switches `rhd_r01`, `rhd_r02`, or `rhd_r03` to choose a radiation transport module. The others have reasonable default values. To find the combination with the optimal performance, you should look into Sect. 3.8

The macros are sorted into different categories:

Some *activate a certain feature* (like a radiation transport module or the dust module). They have to be selected by the user (typically via environment variables and the configure script, see Sect. 3.6) each time the code is compiled for a certain purpose.

Other macros are meant to *improve the performance* by offering the choice between e.g. different loop structures or case distinctions. These macros are set by the configure script to the best knowledge of the author(s). Ideally, they should be checked and modified if necessary each time CO5BOLD is compiled on a new machine. It should be save to modify these settings: the results between runs with different settings should only differ slightly due to round-off errors.

Some macros *select between different numerical approximations*. A change here should be visible in a (more or less drastic) change of the results of a simulation. Usually, the default values should be accepted. Other settings typically only exist to allow the comparison with older versions of CO5BOLD or because there are new developments going on which have not yet managed to become the default.

A couple of macros only activate timing measurements and result in *additional output*. Some of them are not thread-save und should only be activated for runs on one thread (as done by the configure script). It is always save to switch any of them off (by removing or undefining them).

The macros in the category *test* mark parts of code under development. The default values should only be changed with great care (typically by the author of that code segment). The configure script does not touch these settings.

General:

- **timing\_c\_factor:**

in `timing_module.F90`, (“timing count factor”).

Category: account for property of machine.

To produce the timing statistics printed at the end of a simulation run the standard Fortran routine `SYSTEM_CLOCK` is used. The macro `timing_c_factor` specifies by how much the count rate of this routine is reduced when storing its count value. This does not prevent all overflows but can make the output much more useful. Values:

- 1: (default) count rate of `SYSTEM_CLOCK` is used directly.
- otherwise: e.g. 1000, count rate of `SYSTEM_CLOCK` is reduced by this factor.

By a proper choice of this factor the timing measurements of individual routines can be made meaningful: the reduction of the count rate prevents overflows due to the addition of several measurements. An overflow during an individual measurement can not be prevented. Therefore, the count rate for the entire program still tends to produce overflows.

- **gasinter\_l01:**

in `gasinter_routines.F90`, (“gas interpolation l01”).

Category: performance enhancement.

This switch determines how temporary arrays are handled to improve performance Values:

- 0: (default) Temporary coefficient arrays are actually copied.
- 1: Temporary coefficient arrays just get a pointer link into the big arrays.

- **rhd\_box\_grav01:**

in `rhd_box_module.F90`, (“rhd box gravitation 01”).

Category: feature activation.

Switch to activate the array for the gravitational potential in the box structure. If the switch is set to 1, a 3D array for the potential is created, copied, removed, ... There is no module to compute the gravitational potential, yet. Therefore the entire thing has no practical value, yet. Values:

- 0: (default) no handling of array.
- 1: array handling activated.

- **rhd\_box\_quc01:**

in `rhd_box_module.F90` and `rhd.F90`, (“rhd box quantity centered 01”).

Category: feature activation.

Now, CO5BOLD is able to handle a number of additional quantities (e.g. density arrays) in addition to the basic hydrodynamics quantities ( $\rho$ ,  $e_i$ , ...) if this compiler switch is activated. These additional quantities can be e.g. densities of dust distribution moments or densities of molecules. Values:

- 0: (default) no handling of additional quantities (density arrays).
- 1: handling of additional density arrays is activated.

To actually include dust formation in a simulation, it is necessary to

1. set the switch `-Drhd_box_quc01=1` during compilation (this is done by the configure script if the environment variable `F90_DUST` is set to 1, see the description of the variable in Sect. 3.6),
2. put arrays specifying the initial conditions of the additional density into the start model (as `real quc001`, `real quc002`, ...),
3. select a proper model describing dust (or molecule) formation in the parameter file (with `character dustscheme`).

- `rhd_box_bmag01`:

in `rhd_box_module.F90` and `rhd.F90`, (“rhd box b magnetic 01”).

Category: feature activation.

CO5BOLD can handle magnetic field arrays if this compiler switch is set. Values:

- : (default) no handling of magnetic field arrays.
- : handling of magnetic field arrays is activated.

To actually account for magnetic fields in a simulation, it is necessary to

1. set the switch `-Drhd_box_bmag01=1` during compilation (this is done by the configure script if the environment variable `F90_MHD` is set to 1, see Sect. 3.6),
2. put arrays specifying the initial conditions of the boundary centered magnetic field arrays into the start model (as `real bb1`, `real bb2`, `real bb3`),
3. select an hydrodynamics scheme that is able to handle magnetic fields in the parameter file (with `character hdscheme`).

Hydrodynamics (Roe solver):

- `rhd_roe1d_slope_101`:

in `rhd_hyd_module.F90`, (“rhd roe 1 dimension slope loop 01”).

Category: feature activation.

When this compiler switch is set, a new extra stabilization mechanism can be activated: If one of the reconstruction methods `VanLeer`, `Superbee`, or `PP` (see Sect. 5.3.7) is activated, the slope can be reduced (by averaging with the results from a `MinMod` reconstruction) by setting `c_slopered` (see Sect. 5.3.7) to a positive non-zero value. This can improve the stability without significantly reducing the effective numerical resolution. Switch values:

- 0: (default) no slope reduction.
- 1: slope reduction in case of expansion wave.
- 2: slope reduction in case of strong density contrast.

- `IDF`:

in `rhd_hyd_module.F90`, (“Integer Delta Flux”).

Category: performance enhancement.

Number of padding cells for flux-like variables. This number was introduced to check whether the increase of the size of vectors for flux-like quantities (defined at cell boundaries) can improve the performance (especially on a CRAY machine). The gain is marginal (if present at all). The parameter is usually set to zero or left undefined. Values:

- 0: (default) no padding cells
  - 1,2,3,...: extra padding cells
- **rhd\_hyd\_gravcorr\_p01:**  
in `rhd_hyd_module.F90`, (“rhd hydrodynamics gravitation correction parameter 01”).  
Category: selection of approximation.  
This parameter controls the way the Roe solver handles the source terms due to gravity. A different choice results in different simulation results and not just in slightly faster (or slower) code. The problem is that the original Roe solver interpretes the pressure gradient in a hydrostatic stratification a fluctuation due to shock waves. In case of strong stratification this can lead to weird effects. With activated correction the Roe solver treats only the deviations from a hydrostatic stratification as due to waves (or shocks). Several correction formulas have been tried. The latest is the recommended default. Values:
    - 0: No pressure correction terms in Roe solver.
    - 1: Simple correction with rhomean, no new average pressure.
    - 2: Simple correction with rhomean, new average pressure.
    - 3: Correction with local rho, limited, new average pressure.
    - 4: Correction with local rho, new (different formula) average pressure.
    - 5: (default) Correction with local rho, new limit, new average pressure.
  - **rhd\_hyd\_entropyfix\_p01:**  
in `rhd_hyd_module.F90`, (“rhd hydrodynamics entropy fix parameter 01”).  
Category: performance enhancement.  
The entropy fix can be done in one of two ways to get optimum performance (with essentially the same results). Values:
    - 0: (default) “if...then...else” construction
    - 1: use a mask and the signum function
  - **rhd\_hyd\_upwind\_p01:**  
in `rhd_hyd_module.F90`, (“rhd hydrodynamics upwind parameter 01”).  
Category: performance enhancement.  
The determination of the upwind direction can be done in one of two ways to get optimum performance (with essentially the same results). Values:
    - 0: (default) “if...then...else” construction
    - 1: use a mask and the signum function
  - **rhd\_hyd\_roe1d\_l01:**  
in `rhd_hyd_module.F90`, (“rhd hydrodynamics roe 1 dimension loop 01”).  
Category: performance enhancement.  
The computation of the Roe fluxes can be done by either of two sets of routines to find the set which gives optimum performance (with essentially the same results). Values:
    - 0: (default) lots of small routines acting on scalars, inlining needed, cache reuse is optimized
    - 1: routines acting on arrays, more temporary arrays necessary, vectorization is easier
  - **rhd\_roe1d\_flux\_l01:**  
in `rhd_hyd_module.F90`, (“rhd roe 1 dimension flux loop 01”).  
Category: test.  
By setting this switch an alternative way of computing the upwind centered Roe states is activated (only for 'constant' reconstruction, for performance test purposes only: do not activate!). Values:

- **undefined:** (default) Use standard method to compute the Roe states.
  - **defined:** Use non-standard method to compute the Roe states.
- **rhdbound\_t01:**  
in `rhdbound_module.F90`, (“rhdbound timing 01”).  
Category: additional output.  
Produce timing information for “inner boundary” routine (central potential) or lower and upper boundary routines (constant gravitation). It can be used together with OpenMP.  
Values:
    - **undefined:** (default) no timing information.
    - **defined:** call subroutines to measure elapsed time.
  - **rhdroe1d\_flux\_t01:**  
in `rhdroe1d_flux_module.F90`, (“rhdroe 1 dimension flux timing 01”).  
Category: additional output.  
Produce timing information for the routine which computes the Roe fluxes. It should not be used in conjunction with OpenMP. Values:
    - **undefined:** (default) no timing information
    - **defined:** call subroutines to measure elapsed time
  - **rhdroe1d\_step\_t01:**  
in `rhdroe1d_step_module.F90`, (“rhdroe 1 dimension step timing 01”).  
Category: additional output.  
Produce timing information for the routine which performs the Roe step. It should not be used in conjunction with OpenMP. Values:
    - **undefined:** (default) no timing information
    - **defined:** call subroutines to measure elapsed time

#### Hydrodynamics (tensor viscosity):

- **rhdrhoavg\_p01:**  
in `rhdrhoavg_module.F90`, (“rhdrhoavg density parameter 01”).  
Category: selection of approximation.  
Choose formula for density average at cell boundary in tensor viscosity routines. Values:
  - 0:  $\rho_{\text{mean}} = \min(\rho_{\text{left}}, \rho_{\text{right}})$
  - 1: (default)  $\rho_{\text{mean}} = 0.5 * (\rho_{\text{left}} + \rho_{\text{right}})$
- **rhdrhoavg\_t01:**  
in `rhdrhoavg_module.F90`, (“rhdrhoavg timing 01”).  
Category: additional output.  
Produce timing information for 2D/3D tensor viscosity routines. It should not be used in conjunction with OpenMP. Values:
  - **undefined:** (default) no timing information
  - **defined:** call subroutines to measure elapsed time

#### Radiation transport:

- **rhdrad:**  
in `rhdrad.F90`, (“rhdrad radiation 01”).  
Category: feature activation.  
Switch to include LHDrad radiation transport module. It uses long characteristics and is restricted to an equidistant grid and open boundaries at all surfaces (old “supergiant module”). Values:

- **undefined:** (default) LHDrad routines are deactivated.
  - **1:** LHDrad routines are recognized by the compiler.
- **rhd\_r02:**  
in `rhd.F90`, (“rhd radiation 02”).  
Category: feature activation.  
Switch to include MSrad radiation transport module. It uses long characteristics. The lateral boundaries have to be periodic. Top and bottom can be closed or open (“solar module”). Values:
  - **undefined:** (default) MSrad routines are deactivated.
  - **1:** MSrad routines are recognized by the compiler.
- **rhd\_r03:**  
in `rhd.F90`, (“rhd radiation 03”).  
Category: feature activation.  
Switch to include SHORTrad radiation transport module. It uses short characteristics and is restricted to an equidistant grid and open boundaries at all surfaces (new “supergiant module”). Values:
  - **undefined:** (default) SHORTrad routines are deactivated.
  - **1:** SHORTrad routines are recognized by the compiler.
- **rhd\_rad3d\_toray\_l01:**  
in `rhd_lhgrad_module.F90`, (“rhd radiation 3 dimensions to ray loop 01”).  
Category: performance enhancement.  
There might be a performance gain by splitting the main loop in routine `rhd_rad3d_toray` into three separate loops. Typically, one big loop is to be preferred. Values:
  - **undefined:** (default) One big loop
  - **defined:** Three smaller loops
- **rhd\_rad3d\_fromray\_l01:**  
in `rhd_lhgrad_module.F90`, (“rhd radiation 3 dimensions from ray loop 01”).  
Category: performance enhancement.  
There might be a performance gain by splitting a big loop in routine `rhd_rad3d_fromray` into two separate loops. Typically, one big loop is to be preferred. Values:
  - **undefined:** (default) One big loop
  - **defined:** Two smaller loops
- **rhd\_rad3d\_r02:**  
in `rhd_lhgrad_module.F90`, (“rhd radiation 3 dimensions radiation 02”).  
Category: test.  
Module `rhd_lhgrad_module` contains a routine for the handling of periodic boundaries. It is in an experimental state and is deactivated by default. Values:
  - **undefined:** (default) Skip routine `rhd_rad3d_dirper` during compilation
  - **defined:** Compile routine `rhd_rad3d_dirper`
- **rhd\_rad3d\_solve\_t01:**  
in `rhd_lhgrad_module.F90`, (“rhd radiation 3 dimensions solve timing 01”).  
Category: additional output.  
Produce timing information for the routines which solves the 1D radiation transport equation along single ray. This routine is called very frequently. The timing measurement might slow it down somewhat. It should not be used in conjunction with OpenMP. Values:

- undefined: (default) no timing information
  - defined: call subroutines to measure elapsed time
- **rh\_d\_rad3d\_dir\_t01:**  
in `rh_d_lh_drad_module.F90`, (“rh\_d radiation 3 dimensions direction timing 01”).  
Category: additional output.  
Produce timing information for the routines which solves the radiation transport equation for one direction field. The timing measurement are called very frequently and might slow down the code. It should not be used in conjunction with OpenMP. Values:
    - undefined: (default) no timing information
    - defined: call subroutines to measure elapsed time
  - **rh\_d\_rad3d\_step\_t01:**  
in `rh_d_lh_drad_module.F90`, (“rh\_d radiation 3 dimensions step timing 01”).  
Category: additional output.  
Produce timing information with main 3D radiation transport routine. It can be used together with OpenMP and should cause no noticeable performance loss. Values:
    - undefined: (default) no timing information
    - defined: call subroutines to measure elapsed time
  - **rh\_d\_shortrad\_operator\_l01:**  
in `rh_d_shortrad_module.F90`, (“rh\_d short-characteristics radiation operator loop 01”).  
Category: performance enhancement, selection of approximation.  
Choose type of short characteristics operator. The operators usually come in pairs (1/2, 3/4, 5/6). There is a development from 1/2 over 3/4 to 5/6 towards higher stability. Both members of each pair should do the same operation but use different ways to do a case distinction. The ‘even’ operator has in most case the better performance. But the ‘odd’ operator might be saver to use. Values:
    - 0: simple test operator, fast but results are utterly useless!
    - 1: case distinction with “if..then..else” construct.
    - 2: case distinction with masks (weights 0.0 or 1.0).
    - 3: case distinction with “if..then..else” construct, slope reduction of source function.
    - 4: case distinction with masks (weights 0.0 or 1.0), slope reduction of source function.
    - 5: case distinction with “if..then..else” construct, modified slope reduction of source function.
    - 6: (default) case distinction with masks (weights 0.0 or 1.0), modified slope reduction of source function.
    - 8: test version.
  - **rh\_d\_shortrad\_operator\_l02:**  
in `rh_d_shortrad_module.F90`, (“rh\_d short-characteristics radiation operator loop 02”).  
Category: performance enhancement.  
Select the way the short characteristics operator is accessed. Values:
    - 0: (default) The routine with the short characteristics operator is called within a loop and should be inlined.
    - 1: The program fragment with the short characteristics operator is included. No inlining necessary.



- **rhd\_shortrad\_dtauop\_101:**  
in `rhd_shortrad_module.F90`, (“rhd short-characteristics radiation delta tau operator loop 01”).  
Category: performance enhancement.  
Choose type of short characteristics tau coupling operator. Values:
  - 1: case distinction with “if..then..else” construct, default if `rhd_shortrad_operator_101=1,3,5`.
  - 2: case distinction with masks (weights 0.0 or 1.0), default if `rhd_shortrad_operator_101=2,4,6`.
  
- **rhd\_shortrad\_dtauop\_102:**  
in `rhd_shortrad_module.F90`, (“rhd short-characteristics radiation delta tau operator loop 02”).  
Category: performance enhancement.  
Select the way the operator for the tau coupling (short characteristics module) is accessed.  
Values:
  - 0: (default) The routine with the tau coupling operator is called within a loop and should be inlined.
  - 1: The program fragment with the tau coupling operator is included. No inlining necessary.
  
- **rhd\_shortrad\_formal\_101:**  
in `rhd_shortrad_module.F90`, (“rhd short-characteristics radiation formal loop 01”).  
Category: performance enhancement.  
Select version of loop splitting for  $\exp(-d\tau)$  computation. Values:
  - 0: (default) `dtauhalf`, `exp_mdtauhalf`, `expl2t_mdtauhalf` are computed in single loop
  - 1: (`dtauhalf`, `exp_mdtauhalf`), (`expl2t_mdtauhalf`) are computed in separate loops. This prevents the SUN1 machine (Sunfire, Solaris, Forte 6.2) from doing some performance degrading optimization
  
- **rhd\_shortrad\_dir1\_101:**  
in `rhd_shortrad_module.F90`, (“rhd short-characteristics radiation direction 1 loop 01”).  
Category: performance enhancement.  
Choose routine version for rays in x1 direction. Values:
  - 0: (default) Use routine with permuted indices for rays in x1 direction. In this case the innermost loop index is the third array index. The transposition of arrays is not needed but some machines (e.g. SUN1) do not like this index arrangement.
  - 1: Transpose arrays and use routine `rhd_shortrad_dir3` for rays in x1 direction. The extra step for the transposition of some arrays (and the reverse procedure) needs some time. But now the routine with the optimum index ordering can be used.
  
- **rhd\_shortrad\_dir\_102:**  
in `rhd_shortrad_module.F90`, (“rhd short-characteristics radiation direction loop 02”).  
Category: performance enhancement.  
Determine position of PARALLEL statement relative to outer loop in `rhd_shortrad_dirX`. Both settings give the same results but might show a different performance on a specific machine. Values:
  - 0: (default) PARALLEL statement inside of outer loop
  - 1: PARALLEL statement outside of outer loop

- **rhd\_shortrad\_lambda\_l01:**  
in `rhd_shortrad_module.F90`, (“rhd short-characteristics radiation lambda loop 01”).  
Category: feature activation.  
Handling of extra arrays to allow partially implicit Lambda\* iteration Values:
  - 0: (default) Only fully implicit Lambda\* iteration allowed (or fully explicit treatment).
  - 1: Also partially implicit Lambda\* iteration allowed.
- **rhd\_shortrad\_formal\_t01:**  
in `rhd_shortrad_module.F90`, (“rhd short-characteristics radiation formal timing 01”).  
Category: additional output.  
Produce timing information for routine which gives the formal solution of the radiation transport equation with the help of short characteristics. It can be used together with OpenMP and should cause no noticeable performance loss. Values:
  - `undefined`: (default) no timing information
  - `defined`: call subroutines to measure elapsed time
- **rhd\_shortrad\_step\_t01:**  
in `rhd_shortrad_module.F90`, (“rhd short-characteristics radiation step timing 01”).  
Category: additional output.  
Produce timing information for main short characteristics routine. It can be used together with OpenMP and should cause no noticeable performance loss. Values:
  - `undefined`: (default) no timing information
  - `defined`: call subroutines to measure elapsed time
- **MSrad\_raytas:**  
in `MSrad3D.F90`, (“Matthias Steffen radiation ray tau s”).  
Category: performance enhancement.  
Values:
  - 0: (default) Loop with `IF..THEN..ELSE`
  - 1: Loop with `ABS,SIGN`
  - 2: Loop with `MIN,MAX`

### 3.8 Optimization, Compiler Switches

In this section some mandatory or useful compiler flags are described. These have different functions:

- Enable necessary macro processing/expansion for the F90 files.
- Force proper handling of binary I/O.
- Choose module for radiative transfer.
- Activate module for dust formation and/or magnetic field transport.
- Enable parallelization with OpenMP directives.
- Choose a version of a subroutine or loop which is optimized for a specific architecture.
- Tell the compiler if and what to inline.
- Improve the general performance.

### 3.8.1 Cray: SV1

On craSHi in Kiel (a “CRAY SV1 20-32768 SN9542”, now out of service) CO5BOLD could use all 4 processors per board. Documentation about the system and the compiler can be found with the CRAYdoc<sup>1</sup> system. The new configure script still includes a branch for this system even if has never been tested on that machine.

In some cases the non-default versions of loops in the CO5BOLD code vectorize better and are preferred over the standard ones:

- `-F`: Enable macro expansion
- `-Otask1`: Parallelization: Enable tasking (in this case OpenMP).
- `-Oinline3`: Optimization: enable (high level) of inlining.
- `-Ovector3 -Oscalar3`: General optimization
- `-Drhd_hyd_roe1d_l01=1`: Optimization: Choose non-standard set of routines for Roe solver. See Sect. 3.7.
- `-Drhd_hyd_entropyfix_p01=1`: Optimization: version with masks (weights). See Sect. 3.7
- `-Drhd_hyd_upwind_p01=1`: Optimization: version with masks (weights).
- `-Drhd_shortrad_operator_l01=2`: Optimization: short characteristics operator with masks (weights).
- `-Drhd_shortrad_dir_l02=1`: Optimization: OMP PARALLEL statement outside of outer loop in `rhd_shortrad_dirX`.

### 3.8.2 Compaq: alpha

Documentation about the Compaq Fortran compiler<sup>2</sup>.

The appropriate machine dependent UIO module is `uio_mac_decalpha_module.f90`.

- `-assume byterecl`: Necessary for the UIO routines: specify that the length of a record is measured in bytes (and not in words).
- `-cpp`: invoke the preprocessor on all source files.
- `-inline speed -V`: Force automatic inlining, optimized for speed.
- `-O4`: General optimization.
- `-Drhd_hyd_roe1d_l01=0`: Optimization: Choose standard set of routines for Roe solver. See Sect. 3.7.
- `-DMSrad_raytas=0`: Optimization: choose default version of loop in SUBROUTINE `raytas` in file `MSrad3D.F90`. See Sect. 3.7.

### 3.8.3 Hewlett-Packard: V2500

The 12-processor machine “zeipel” from Hewlett-Packard<sup>3</sup> is a “V2500 PA 2.0” system. Now, there is a first success to force the compiler to accept the OpenMP directives in CO5BOLD. Yet, when running on several processors, only some routines (e.g. `rhd_shortrad_dirsimple1`) in CO5BOLD can benefit while others (`rhd_shortrad_dirsimple2`, `rhd_shortrad_dirsimple3`) are significantly slower than on one processor. In addition, the single-processor performance is not very good, partly because the achievable optimization level is not very high.

Some macros, which seem to be necessary:

<sup>1</sup><http://www.cray.com/craydoc/>

<sup>2</sup><http://www.compaq.com/fortran/docs/index.html>

<sup>3</sup><http://devresource.hp.com/devresource/Tools/lang.html>

- `+U77`: Link proper library to make the machine understand e.g. `call flush(6)`.
- `+cpp=yes`: Switch on the C preprocessor. Note that all Fortran90 files have to end with `“.f90”`. The `“.F90”` suffix does not seem to work.
- `+Oparallel +Oopenmp +Onoautopar`: Try to enable parallelization with OpenMP directives, disable auto-parallelization.
- `+Onoinline`: Disables inlining. This can simplify things. With a proper choice of routine versions inlining is not really necessary anymore.
- `+O3 +Olimit`: General optimization with limited resource usage during compilation. Some modules should only be compiled with `+O2`, others compile even with `+O3 +Onolimit`.

The UIO modules and the string handling module should be compiled in debug mode. A proposed compiling sequence is (MSrad does not compile; all other modules are activated):

```
export F90_LHDRAD=1
export F90_MSRAD=0
export F90_SHORTRAD=1
export F90_DUST=1
export F90_MHD=1
export F90_PARALLEL=openmp
```

```
export F90_DEBUG=1
./configure
make UIO STR
```

```
export F90_DEBUG=0
./configure
make
```

### 3.8.4 Hewlett-Packard: Itanium 2

The 2-processor system “gunnar” from Hewlett-Packard is a dual Itanium 2 machine with two 900MHz ia64 CPU modules, 4GB of RAM and 70GB user disk space.

The single-processor performance of CO5BOLD is very good. On two processor the code runs even faster but just stops after a few time steps. The number of time steps varies even for simulations with the very same start model and parameter file. Therefore, OpenMP should not be activated currently.

The compiler settings are somewhat similar to the settings of the HP V2500 system in Section 3.8.3:

- `+U77`: Link proper library to make the machine understand e.g. `call flush(6)`.
- `+cpp=yes`: Switch on the C preprocessor. Note that all Fortran90 files have to end with `“.f90”`. The `“.F90”` suffix does not seem to work.
- `+Ofast`: High optimization level. and `+Ofaster` is even higher.
- `+Oopenmp +Onoautopar`: Try to enable parallelization with OpenMP directives, disable auto-parallelization. The code compiles and runs fast but crashes after a few time steps.

A proposed compiling sequence is (LHDrad, DUST, MHD do not compile):

```
export F90_MSRAD=1
export F90_SHORTRAD=1
./configure
make
```

### 3.8.5 Hitachi SR8000

The appropriate machine dependent UIO module is `uio_mac_hitachi_module.f90`. The appropriate machine dependent RHD module is `rhd_mac_hitachi_module.f90`.

- `-conti199`: Up to 199 continuation lines can be interpreted (otherwise not more than 39 continuation lines are accepted).
- `-limit`: Limits the amount of time and memory for compilation.
- `-opt=ss`: use highest possible optimization level.
- `-nopredicate`: this option switches off a sub-option activated by `opt=ss`. It is necessary to disable the `-predicate` option because the code crashes otherwise (segmentation violation). The switch must appear *after* setting `-opt=ss`.
- `-pvfunc=2`: References the pseudo-vectorizing mathematical function and applies the temporary array to reference the pseudo-vectorizing mathematical function.
- `-omp -parallel=1`: parallelize based on OpenMP directives only.
- `-procnun=8`: generated code for 8 processors on one node
- `-orphaned=1`: Checks if the regions sequentially executed contain orphaned directives during run-time when `PROCNUM=8` is specified. If a sequentially executed region contains an orphaned directive, the system outputs a message and terminates the program.
- `-nestcheck=1`: Checks for nesting errors in parallel regions. If a parallel region is nested, the system returns an error and terminates the program. *Without this option, the code aborts with an error message, indicating illegal nesting. Compiler bug?*
- `-pmpar`: Collects the performance monitor information for each parallelization unit.
- `-pmfunc`: Collects the performance monitor information for each procedure.
- `-Drhd_hyd_roe1d_l01=1`: Optimization: Choose non-standard set of routines for Roe solver. See Sect. 3.7.
- `-DMSrad_raytas=0`: Optimization: choose default version of loop in SUBROUTINE `raytas` in file `MSrad3D.F90`. See Sect. 3.7.
- **Important note**: The UIO routines need in addition the compiler option `-subchk`: Array bound checking. Without this checking option, some UIO routines are not working properly (compiler bug?).

A proposed compiling sequence is (only default modules activated):

```
export F90_PREFLAGS="-subchk"
./configure
make UIO

export F90_PREFLAGS=
./configure
make
```

### Performance tests on hwwsr8k

Some tests have been performed on the machine `hwwsr8k` at HLR Stuttgart in order to determine the optimum chunk sizes which are set by the parameters `n_hydcellspchunk` and `n_viscellspchunk` (see Sect. 5.3.7 and Sect. 5.3.8). Two different models have been used, one

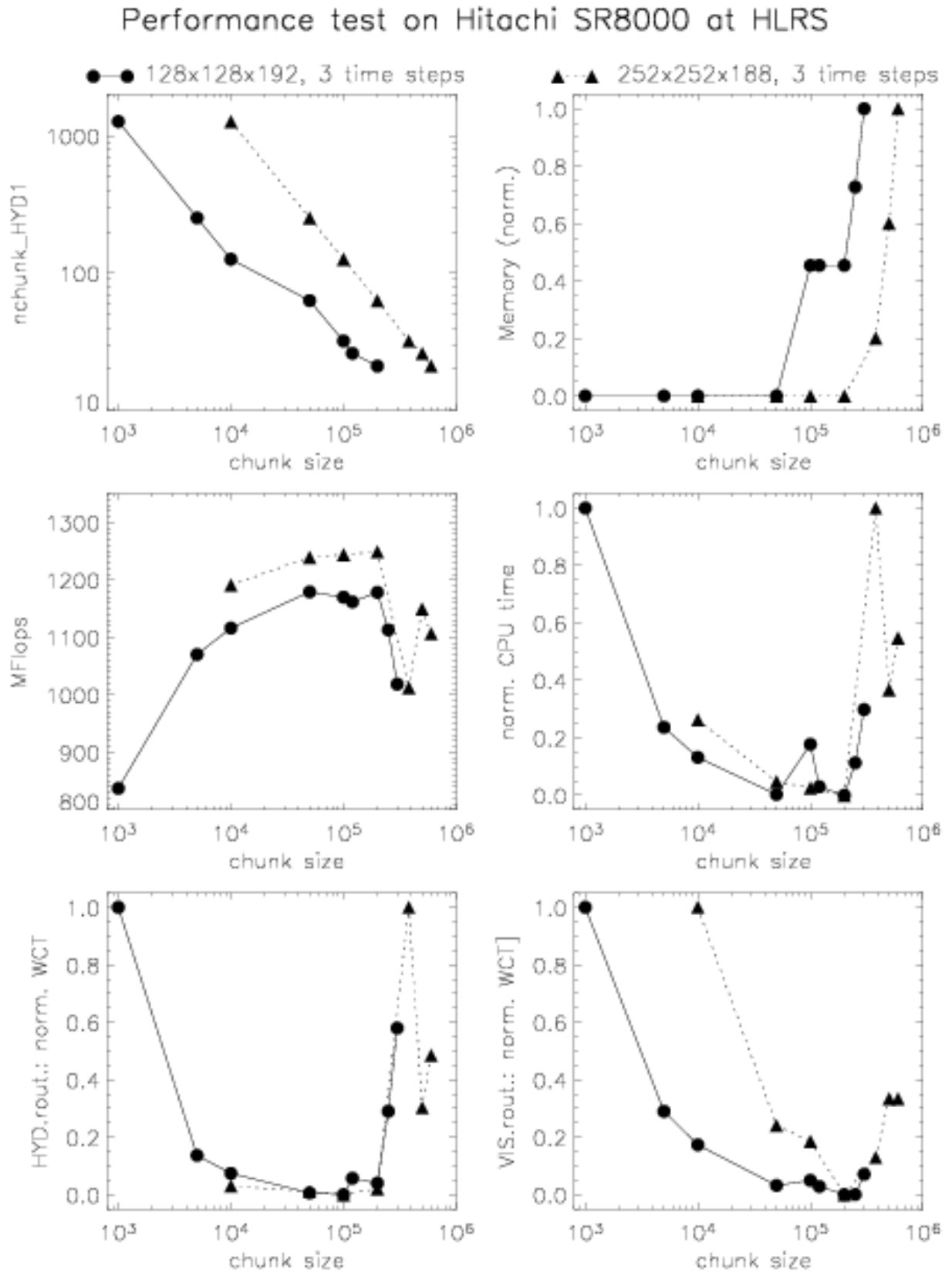

Figure 2: Performance tests on Hitachi SR8000 at HLR Stuttgart. For models with  $128 \times 128 \times 192$  and  $252 \times 252 \times 188$  grid cells different values for the hydrodynamics and viscosity chunk size parameters were used. See text for more details.

consisting of 128x128x192 grid cells, the other of 252x252x188, respectively. Grey radiative transfer has been performed with the MSrad module. Different values for the chunk size(s) have been assumed where the hydrodynamics and the viscosity parameter were set equal. In all cases three time steps have been computed. The results are shown in Fig. 2. The number of resulting chunks for step HYD1 (the values for HYD2, HYD3, and VIS are very similar), total memory, performance, and the wall clock duration of the hydrodynamics and the viscosity routines are shown as functions of the chunk size parameter(s). Clearly, the number of chunks decreases towards larger chunk sizes whereas the required memory increases – in particular for very large chunk size values. Moreover, performance and CPU time can be optimised by choosing the right parameter values. Interestingly, the optimum chunk size is different for hydrodynamics and viscosity. Based on these tests, a larger value seems to be preferable for the viscosity (`n_viscellsperchunk`). In the case of the smaller model, 50000 seems to be fine for the hydrodynamics whereas the optimum viscosity chunk size is 200000. This difference explains the double-peaked structure of performance and CPU time. Note that the optimum values do not only depend on the architecture used but also on the dimensions of the model. We recommend to test some chunk size values since it might lead to a higher performance.

### 3.8.6 Linux: PGI Compiler

So far, under Linux the compiler of the Portland Group<sup>4</sup> has been used mostly to compile CO5BOLD. It is called with `pgf90`.

Important switches are:

- `-byteswapio`: With this flag set, binary files in `big_endian` format (the standard for UIO files) are automatically transformed to `little_endian` and vice versa.
- `-fast`: General optimization flag to choose (close to) optimum optimization for local machine.
- `-Mvect=sse`: Optimization: Allow Pentium III vector commands.
- `-Mcache_align`: Optimization: Align some data object on cache-line boundaries.
- `-fastsse`: From compiler version 4.0 on, this option can be used instead of the three previous ones. It contains and supersedes them.
- `-Minline=...`: Optimization: Routines that should be inlined:  

```
file rhd_hyd_module.F90:    rhd_hyd_avg,    rhd_hyd_upwind,    rhd_hyd_pred0,
rhd_hyd_predm,    rhd_hyd_predp,    rhd_hyd_alpha,    rhd_hyd_constanteq,
rhd_hyd_minmodeq,    rhd_hyd_minmod,    rhd_hyd_vanleereq,    rhd_hyd_vanleer,
rhd_hyd_superbeeeq, rhd_hyd_superbee, rhd_hyd_ppeq, rhd_hyd_pp, rhd_hyd_hdflux,
file rhd_lhtrad_module.F90:    rhd_rad3d_raylhd,    rhd_rad3d_solve,
rhd_rad3d_solveeq,
file rhd_shortrad_module.F90: rhd_shortrad_operator, rhd_shortrad_dtauop.
```
- `-DMSrad_raytas=2`: Optimization: choose non-default version of loop in SUBROUTINE `raytas` in file `MSrad3D.F90`. See Sect. 3.7.
- `-Drhd_hyd_roe1d_101=0`: Optimization: choose standard set of routines for Roe solver. See Sect. 3.7.
- `-Drhd_shortrad_operator_102=1`: Optimization: use the “manually inlined version” of the short characteristics operator.
- `-Drhd_shortrad_dtauop_102=1`: Optimization: use the “manually inlined version” of the optical coupling operator.

Everything compiles. The MSrad radiation transport module does not work with OpenMP activated. In this case it is recommended to use the Intel compiler instead (see Sect. 3.8.7).

---

<sup>4</sup><http://www.pgroup.com/>

### 3.8.7 Linux: Intel Compiler

With Version 7.0 of the Intel compiler<sup>5</sup> CO5BOLD compiles.

The native format on Intel machines is `little_endian`. With

```
export F_UFMTENDIAN=big
```

(to be set at runtime after compilation before running CO5BOLD) the default can be changed to `big_endian`. The appropriate UIO modules are `uio_mac_intel_module.f90` in the `little_endian` case and `uio_mac_sun_module.f90` in the `big_endian` case. The compiler is called with `ifc`.

Important switches are:

- `-Vaxlib`: Link proper library to make the machine understand e.g. `call flush(6)`.
- `fpp`: Activate the preprocessor (silently).
- `-O3`: General optimization flag.
- `-tpp6 -xK`: Optimization especially for Pentium III (includes SSE vector commands).
- `-ip`: Optimization: activate interprocedural optimization within each source file. This enables inlining.
- `-DMSrad_raytas=2`: Optimization: choose non-default version of loop in SUBROUTINE `raytas` in file `MSrad3D.F90`. See Sect. 3.7.
- `-Drhd_shorttrad_dir1_l01=1`: Optimization: Transpose arrays and use routine `rhd_shorttrad_dir3` for rays in `x1` direction. See Sect. 3.7.
- `-openmp`: Parallelization: OpenMP directive are activated. Note that the UIO routines should be compiled without OpenMP support (even if they do not contain any OpenMP directives themselves).

Using the Intel compiler there is a problem with the UIO modules when OpenMP is activated. This is a bit weird because the UIO modules do not contain any OpenMP directives. However, this means that OpenMP can be safely deactivated for these modules. A proposed compiling sequence is (all modules activated):

```
export F90_LHDRAD=1
export F90_MS RAD=1
export F90_SHORTRAD=1
export F90_DUST=1
export F90_MHD=1

export F90_PARALLEL=scalar
./configure
make UIO

export F90_PARALLEL=openmp
./configure
make
```

---

<sup>5</sup><http://www.intel.com/software/products/compilers/flin/index.htm>



### 3.8.8 NEC SX-5

First attempts to compile CO5BOLD on neSH at the Rechenzentrum Kiel and on hwwsx5 at HLR Stuttgart:

An environment variable has to be set to `F_RECLUNIT=BYTE` (before execution of a program) to enable UIO to compute proper record lengths. The cross compiler (on sunsrv or crossi) is called with `sxf90`. Thus, the environment variable `F90_COMPILER=sx90` has to be set before running the configure script.

No optimized version of CO5BOLD has been achieved yet.

Some maybe useful switches are

- `sx5`: generate instructions for SX-5
- `C vopt`: normal optimization in vector mode
- `-Wf' -M noflunf -M noinv -M noinexact -M setall'`: suppress some exceptions
- `-P openmp`: parallelization with OpenMP
- `-Ep`: call cpp preprocessor
- `-pi exp=...`: inlining
- `-dw -float0` (no special environment variable): use internally and in files the 4Byte `big_endian` format

The compiler flags in the configure script are

```
F90FLAGS="-C hopt -sx5 -dw -float0
-Wf'-L nostdout -L fmtlist -L inclist -L mrgmsg -L transform -M noflunf
-M noinv -M noinexact -M setall'
-pi exp=rhd_shortrad_operator exp=rhd_shortrad_dtauop ${F90MODULES}
${F90TIME} -DMSrad_raytas=1"
```

### 3.8.9 SGI: Origin

CO5BOLD has been compiled and tested on up to 8 processors on the SGI 2000 machine at TAC in Copenhagen and the SGI 3800 machine at the NSC<sup>6</sup> in Linköping. See e.g. the excellent SGI Fortran90 manual<sup>7</sup>. Note, that recent versions of the code (or the configure script) have not been tested on any SGI machine.

Important switches are:

- `-macro_expand`: Enable macro expansion
- `-mp`: Enable parallelization with OpenMP directives
- `-INLINE:aggressive=ON -INLINE:list -INLINE:preempt=ON`: General keywords for inlining
- `-INLINE:must=...`: Optimization: Routines that should be inlined:
 

```
file rhd_hyd_module.F90: rhd_hyd_avg, rhd_hyd_upwind, rhd_hyd_pred0,
rhd_hyd_predm, rhd_hyd_predp, rhd_hyd_alpha, rhd_hyd_constanteq,
rhd_hyd_minmodeq, rhd_hyd_minmod, rhd_hyd_vanleereq, rhd_hyd_vanleer,
rhd_hyd_superbeeeq, rhd_hyd_superbee, rhd_hyd_ppeq, rhd_hyd_pp, rhd_hyd_hdflux,
file rhd_lhdrad_module.F90: rhd_rad3d_raylhd, rhd_rad3d_solve,
rhd_rad3d_solveeq,
file rhd_shortrad_module.F90: rhd_shortrad_operator, rhd_shortrad_dtauop.
```

<sup>6</sup><http://www.nsc.liu.se/systems/sgi3k/>

<sup>7</sup><http://techpubs.sgi.com/library/tpl/cgi-bin/init.cgi>

- `-O3 -OPT:Olimit=0`: General optimization
- `-IPA:plimit=5500`: Even more optimization

### 3.8.10 SGI: Origin 2000/3800 at UKAFF

CO5BOLD has been also compiled and tested on up to 22 processors on the machines of the UK Astrophysical Fluids Facility (UKAFF)<sup>8</sup> in Leicester, England. UKAFF operates two machines: an SGI Origin 3800 with 128 processors (named “ukaff”), and an older SGI Origin 2000 with 22 processors (named “grand”) which is mainly used for development and test purposes. Both machines are binary compatible. At the time of testing (April 2003) the SGI MIPSpro Compilers (Version 7.4) was installed.

Most of the compiler switches given in the previous section were used, except for the following modifications which either gave empirically a better performance or were recommended by the UKAFF *Hints for users*:

- `-Ofast`: Replaces `-O3`, gave better performance
- `-LN0:cs1=32k:ls1=32:cs2=8M:ls2=128`: Explicit cache architecture added

These settings are now selected by the configure script for an SGI machine with IP35 architecture. This is rather ad-hoc, and was added in this fashion since the UKAFF machines have this architecture. It is unclear whether the above switches are good for all SGI IP35 architectures.

A glitch in the system libraries made it necessary to add a work-around to the source code (file `rhd.F90`). A “bus error” occurred whenever the system routine “flush” was trying to flush an empty file buffer. The work-around was simply to add a write statement before every call of “flush”. This made the log-file look less nice but did the job.

The main goal was to investigate the scaling of the performance of CO5BOLD with the number of processors. This was done only for the MSrad module, considering local surface convection models. Two model sizes were tested: a small one with 125x125x81 grid points employing non-grey radiative transfer (4 frequency bands), and a large one with 315x315x81 grid points employing grey radiative transfer. Rather short runs of 10 (small model) and 3 (large model) time steps were performed. Even for the large model the memory demand was ca. 800Mb, which is very modest considering that every sub-node of the machine — consisting of 4 processors — has 2Gb of memory.

The results are summarized in the following three figures. The black lines give the scaling of the total time, the green lines the scaling of the time needed by the hydrodynamics routines, and the red lines the scaling of the radiative transfer routines. The scaling is presented as the increase of processing time per processors as the problem is distributed among more and more processors. The times are normalized to the time that is used in a scalar, i.e. single processor setup. Ideally, one would like a constant behavior which stays close to one.

The perhaps most interesting result is that the speedup on “ukaff” is about 11 for the large model on 16 processors. Perhaps not ideal, but within the range of practical interest. In general, the hydrodynamics routines scale more favorably than the radiation routines. This is perhaps simply related to the fact that in explicit hydrodynamics communication is restricted to neighboring grid cells.

For those wondering: the black curves do not lie between the red and green curve since more components than just radiation and hydrodynamics add up to the total time. Furthermore, the normalization of the execution times given by CO5BOLD is not exact.

### 3.8.11 Sun: SunFire

CO5BOLD has been used on the SunFire machines “fire1”, “fire2”, and “fire3” in Uppsala with compiler version “Sun WorkShop 6 update 2 Fortran 95 6.2 2001/05/15” and later. An older

---

<sup>8</sup><http://www.ukaff.ac.uk/>

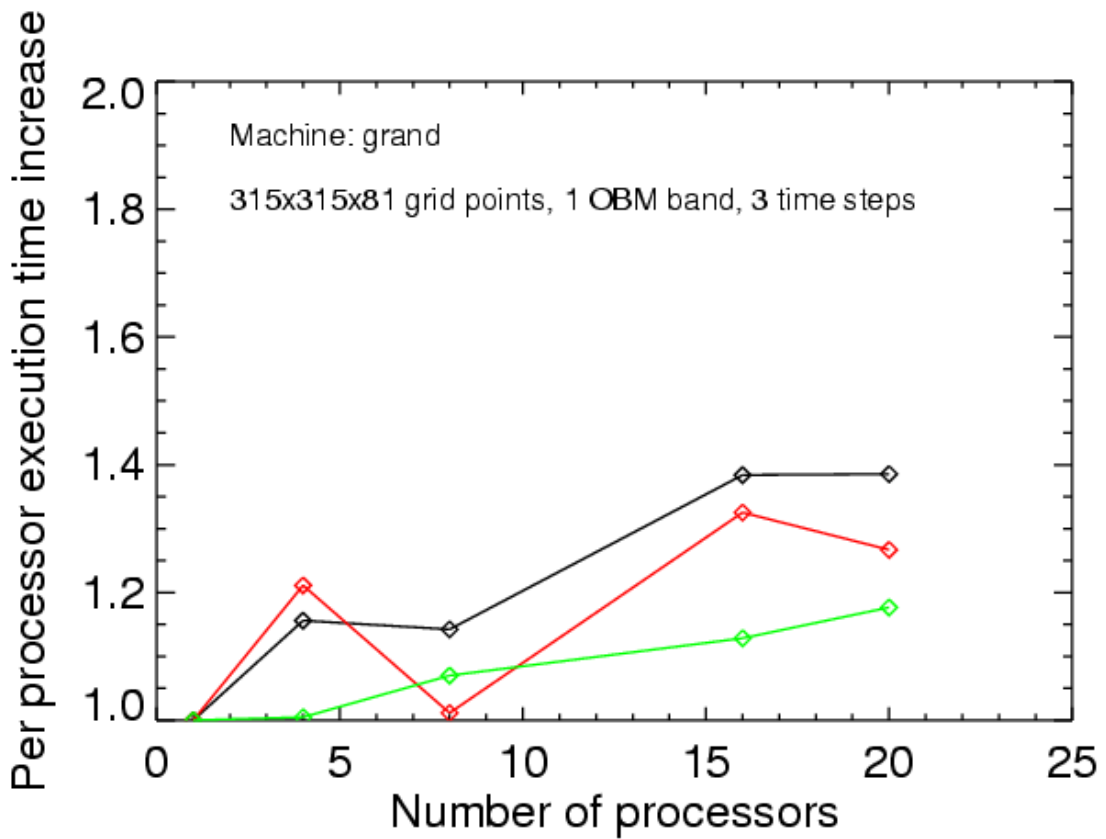
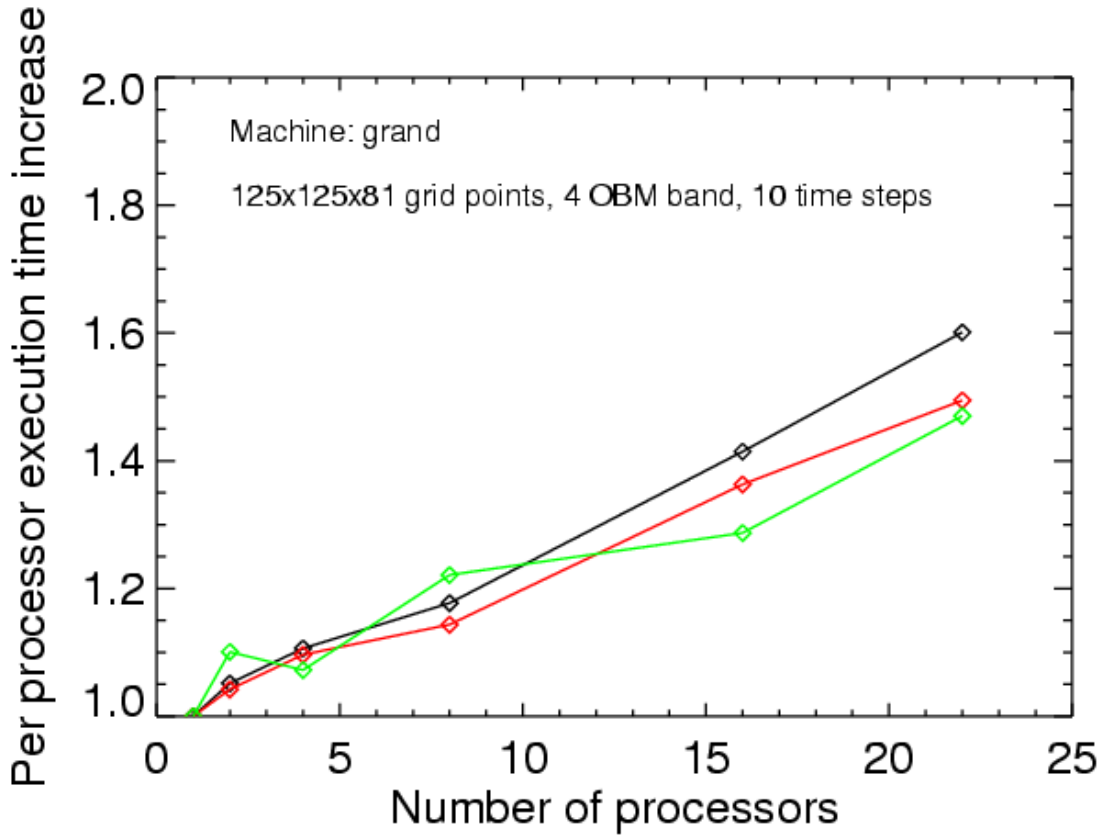

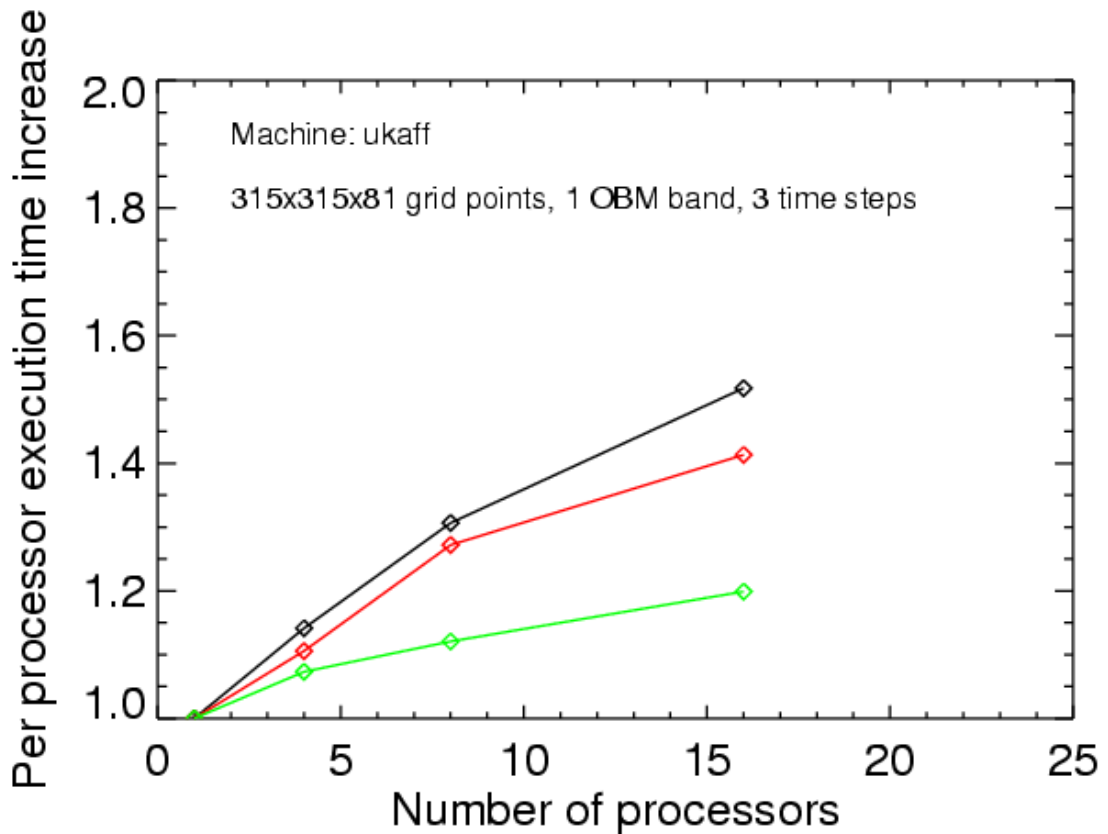

version was not able to compile CO5BOLD properly. Information about Fortran and the Sun compiler can be found on the Sun Forte page<sup>9</sup> under “documentation”. Important switches are:

- `-openmp`: Enable OpenMP.
- `-fast -xvector=yes/no`: General optimization. On the Sun the `-fast` option switches on more or less all optimization features of the compiler. That works reasonable well. However, during the compilation of `gasinter_routines.f90` (and only there) the switch `-xvector=no` is required! This is one automatically in the Makefile.
- `-inline=...`: Optimization: Routines that should be inlined:
 

```
file rhd_hyd_module.F90:  rhd_hyd_avg,  rhd_hyd_upwind,  rhd_hyd_pred0,
rhd_hyd_predm,  rhd_hyd_predp,  rhd_hyd_alpha,  rhd_hyd_constanteq,
rhd_hyd_minmodeq,  rhd_hyd_minmod,  rhd_hyd_vanleereq,  rhd_hyd_vanleer,
rhd_hyd_superbeeeq, rhd_hyd_superbee, rhd_hyd_ppeq, rhd_hyd_pp, rhd_hyd_hdflux,
file rhd_lhtrad_module.F90:  rhd_rad3d_raylhd,  rhd_rad3d_solve,
rhd_rad3d_solveeq,
file rhd_shortrad_module.F90: rhd_shortrad_operator, rhd_shortrad_dtauop.
```
- `-DMSrad_raytas=2`: Optimization: choose non-default version of loop in SUBROUTINE `raytas` in file `MSrad3D.F90`. See Sect. 3.7.
- `-Drhd_shortrad_formal_101=1`: Optimization: split loop for `exp(-dtau)` computation into two loops. See Sect. 3.7.
- `-Drhd_shortrad_dir1_101=1`: Optimization: Transpose arrays and use routine `rhd_shortrad_dir3` for rays in `x1` direction. See Sect. 3.7.
- `-Drhd_hyd_entropyfix_p01=1`: Optimization: version with masks (weights). See Sect. 3.7.

<sup>9</sup><http://www.sun.com/forte/fortran/>

## 4 UIO Data Format

### 4.1 Quickstart: Introduction to UIO

The UIO (“Universal Input Output”) routines are a set of routines in Fortran90 and IDL to manage I/O of scalars, arrays and a certain table type. Files can be formatted or unformatted.

The formatted (ASCII text) data representation is machine-independent and appropriate for human reading.

The unformatted (binary) representation provides much faster I/O, gives smaller files and the IEEE format is a quasi-standard among many platforms/compiler. On all platforms the native binary representation can be chosen. On some machines additional conversion types are offered (IEEE on most machines, CRAY format an CRAYs).

Files produced with UIO are not automatically readable on all machines. But it is always possible to produce (formatted) UIO files on a machine which are readable on all others. And with some fiddling with compile options or the call of machine-specific subroutines provided by the compiler vendor it was up to now always possible to enable the access to binary UIO files on all machine tested.

Each file entry is a header-data-unit. The header contains information on the one hand to identify the entry and on the other hand to specify the format and size of the following data block. This data block usually consists of a scalar or an array. In some cases it is empty (e.g. for labels) or it contains more complex information (for tables).

The first version of UIO routines was written in FORTRAN77. They still exist. But further development was done with the Fortran90 versions. Therefore, the use of the FORTRAN77 routines is not recommended anymore. The current Fortran version of the UIO routines is a set of Fortran90 modules.

To allow a communication between Fortran and IDL programs, an IDL version of the UIO routines has been written. The correspondence between Fortran and IDL routines is rather close. But in detail, there are differences. Currently, IDL Version 5.4 (sunos sparc) is used. Amazingly, the UIO routines also used to work under *PV-WAVE* (Version 6.01 (sun4 solaris sparc)). The UIO routines have been successfully compiled and used on Cray, alpha, HP V2500, HP Itanium2, Hitachi, Linux (with PGI and Intel compiler), SGI, and Sun machines.

So far, there exist three UNIX shell scripts (calling Fortran routines) useful to quickly examine data sets or to change the format or conversion type of files.

### 4.2 Example of UIO Data File

To give a first impression about the data structure, here follows a simple test file, which contains the header, a label, a couple of scalars, an array, and a short table:

```
fileform uio form=formatted convert=native version=0.1.1997.11.29 &
date='29.11.1997 21:23:39.835' system=IRIX machine=atlas osrelease=6.3 &
osversion=12161207 hardware=IP32 language=Fortran90 program=uiotst

label testdata n='sample test data field' date='29.11.1997 21:23:39.835'

integer ia f=I3 b=4 n='This is the answer'
42
complex ca f='''(','E13.6,',''' b=8 n='This is a complex answer'
( 0.400000E+01, 0.200000E+01)
real da f=E23.15 b=8 n='precise answer'
0.4200000000000000E+02
real answer f=F4.0 b=4 n=answer u=1
42.

real real2d d=(100:103,200:204) f=E13.6 p=4 b=4
0.100000E+01 0.200000E+01 0.300000E+01 0.400000E+01
0.500000E+01 0.600000E+01 0.700000E+01 0.800000E+01
0.900000E+01 0.100000E+02 0.110000E+02 0.120000E+02
```

```
0.130000E+02 0.140000E+02 0.150000E+02 0.160000E+02
0.170000E+02 0.180000E+02 0.190000E+02 0.200000E+02
```

```
table f77table d=(1:5,1:7) f=1X b=1 n='test table to test the table routines'
integer  int1 f=I5    b=4 n='Integer: 1. Spalte'
real     real1 f=F5.1 b=4 n='Real: 2. Spalte'
character char1 f=A16 b=16 n='Char: 3. Spalte'
real     real2 f=E13.6 b=4 n='Real: 4. Spalte'
integer  int2 f=I5    b=4 n='Integer: 5. Spalte'
  int1 real1          char1          real2  int2
    1   2.0 a          0.100000E+02    1
    2   4.0 ab         0.200000E+02    2
    3   6.0 abc        0.300000E+02    3
    4   8.0 abcd       0.400000E+02    4
    5  10.0 abcde      0.500000E+02    5
    6  12.0 abcdef     0.600000E+02    6
    7  14.0 abcdefg    0.700000E+02    7
```

### 4.3 Structure of UIO Files

#### 4.3.1 Data Representation: ASCII or Binary

While opening a file for writing, the file format (“formatted” or “unformatted”) and the conversion type (“native”, e.g. “ieee\_4”, ...) have to be specified.

The *formatted* ASCII data representation allows I/O independent of platform or compiler. It is useful for parameter files which can be read and edited by hand, for the direct inspection of data, the transfer between very different systems, or for the import of data which exist e.g. in a table format. From the specified conversion type only the default output format for numbers (e.g. “E13.6” for 4 byte reals) is determined.

The *unformatted* binary I/O is much faster and gives usually more compact files with higher accuracy (ideally exact) in the numerical data representation. But – in principle – the file format is machine dependent. Fortunately, the IEEE format turns out to become a quasi-standard among a variety of machines. Most workstations work internally with this format. Some CRAYS which have a different internal data representation allow the hidden transformation between the internal and IEEE format during the I/O process. The UIO routines support this feature of CRAY FORTRAN compilers by means of a module (`uio_mac_module`) individually designed for (two types of) CRAY machines using certain CRAY specific system calls (CRAY FFIO assign logic). Nevertheless, there is also a machine independent version of this module, written completely in standard Fortran90 but providing less features than the machine-dependent versions.

Besides the format the conversion type (see table 5) has to be specified. The “native” conversion type is the internal binary data representation, which is also standard for unformatted Fortran output. If this representation happens to be conformal with the IEEE standard the conversion type “ieee\_4” should be used. It gives the same data format, but in the header of the file the term “convert=ieee\_4” instead of “convert= native” describes the data format precisely – in a way also understandable by other machines. On CRAY machines the native format is equal to the conversion type “crayxmp\_8”, but also the conversion types “ieee\_4”, “ieee\_4\_limit”, and “ieee\_8” can be chosen. The last three conversion types correspond to the CRAY internal types “ieee\_32”, “ieee\_dp”, and “ieee\_64”, respectively.

On a machine with an internal data representation not within the list in the existing `uio_mac*_module.f90` files one could use the standard file `uio_mac_module.f90` and is restricted to the “native” conversion type. But it is better to invent an appropriate name for the new data format and to build a proper machine dependent UIO file, e.g. from `uio_mac_ieee_module.f90`.

Some attention has to be paid if weird compiler switches (as e.g. `-r16 -i2`) are used to modify the accuracy and standard memory size of variables.

If an existing file is opened for reading, the file format and conversion type are determined automatically from the file if the conversion type of the data in the file is among the conversion

conversion type	I	R	D	description
<b>native</b>	?	?	?	internal data format on all machines (sometimes useful but not recommended)
<b>ieee_4</b>	4	4	8	standard IEEE <b>big_endian</b> format (recommended)
<b>ieeele_4</b>	4	4	8	IEEE <b>little_endian</b> format
<b>ieee_8</b>	8	8	16	double precision IEEE <b>big_endian</b> format (on some machines possible)
<b>crayxmp_8</b>	8	8	16	CRAY internal data format
<b>idl</b>	4	4	8	IDL format (but IDL also supports <b>ieee_4</b> )
<b>xdr</b>	4	4	8	format possible with IDL
<b>ieee_4_limit</b>	4	8	8	standard IEEE format → <b>ieee_4</b>
<b>ieee</b>	?	?	?	IEEE format, unknown length (not recommended)

Table 5: UIO conversion types with length of integers, single precision reals, and double precision reals in bytes, and an explanation.

types supported by the compiler. If the file has a conversion type “native” but is created on a machine with different internal data representation, the file header might be readable, but an error will probably occur during the reading of a real variable.

#### 4.3.2 Data File Structure

The UIO routines only handle sequential files. Each file consists of a list of entries. The first entry describes the file format, conversion type, and the machine who is responsible for it. The following entries contain data (scalars and 1D ... 4D arrays of type integer, real (single & double precision), complex (single precision), character; tables with columns of type integer, real (single precision), or character), or structuring information (labels).

Each entry consists of the header and the (possibly empty) data block.

Each header is a list of at most 20 terms separated by blanks. The first term is the entry type (see table 6), followed by an identifier. This identifier should follow the standard rules for variables (small capital letters, numbers, underline; starting with letter), a name as e.g. `rho`, `v_1`. The rest of the terms come in the form “keyword=value”. See Tab. 7.

entry type	entry contents
<b>fileform</b>	file description (first entry)
<b>integer</b>	scalars, 1D ... 4D arrays
<b>real</b>	scalars, 1D ... 4D arrays, single & double precision
<b>complex</b>	scalars, 1D ... 4D arrays, single precision
<b>character</b>	scalars, 1D ... 4D arrays
<b>table</b>	table with integer, real, character columns
<b>label</b>	label entry for file structuring

Table 6: UIO entry types

A header line has a maximum length of 80 characters. A continuation line is indicated by `␣&` at the end of the line. A header consists of 20 lines at maximum. It can be preceded by empty lines (except for the file header entry). Example:

```
real time f=F9.2 b=4 n='Time' u=s c0='Simulation time in seconds' &
  c1='Time count starts at 0.0'
  12.34
```

The entry header is followed by the entry data block. This block is empty for labels and the `fileform` entry but non-empty otherwise.

keyword	description	example	descriptor	info.	necessary
b	byte number	4	format		yes
d	dimension	(0:9)	format		yes (arrays)
ds	dimension shift	(1:1)		yes	
f	Fortran format	E13.6	format		yes
p	values per line	4	format		yes (arrays)
t	transformation	log10	format		
n	name	density		yes	
u	unit	g/cm <sup>3</sup>		yes	
date	date	1.1.98		yes	
c0...9	comment	Dichte		yes	
form	file format	formatted	file		yes (file header)
convert	conversion	ieee_4	file		yes (file header)
version	version	0.1.1997.11.29		yes	
system	system	IRIX		yes	
machine	machine name	atlas		yes	
osrelease	OS release	6.3		yes	
osversion	OS version	12161207		yes	
hardware	machine hardware	IP32		yes	
language	program. language	Fortran90		yes	
program	program	uiotst		yes	
xyz...	user defined	source		yes	

Table 7: Standard UIO entry header keywords: The keyword is given with a short description and an example. The fourth, fifth, and sixth column indicate if the keyword is a mandatory descriptor (in the file header or for the format of an entry) or if it gives only additional information and is optional and therefore not necessary to specify.

In an *unformatted* file each header line is an individual record containing a string with exactly 80 characters. The following data block (scalar or array) is one single record.

In a *formatted* file each header line is a string of at most 80 characters delimited by a LINEFEED of whatever the operating system decided to be appropriate as EOL character (sequence). The following data block is written as sequence of lines. The number of items per line is specified by the “p=?” keyword in the header.

### 4.3.3 Tables

For a table the entry header is followed by a list of headers for the individual table columns, a single table header line consisting of (abbreviations of) the table entry identifiers and the table itself (see the example in section 4.2). The dimension keyword gives the number of columns and rows in the form “d=(1:columns,1:rows)”.

The Holweger-Müller-Atmosphere is chosen as the following “real world” example for a file with a table in UIO format:

```
fileform uio form=formatted convert=ieee_4 version=0.0.1996.10.29 &
  date='20-Feb-1997 18:40:45' system=SunOS machine=saturn osrelease=4.1.3 &
  osversion=3 hardware=sun4m language='IDL 4.0' program='by hand'
```

```
character description d=(0:3) f=A80 p=1 b=80 d='13-Nov-1996 18:29:48'
Holweger-Mueller-Atmosphere,
Hartmut Holweger & Edith Mueller (1974) Solar Physics 39, 19-30, table II,
empirical solar temperature stratification to fit solar spectral lines and
limb darkening
```

```
character history d=(0:3) f=A80 p=1 b=80 d='13-Nov-1996 18:29:52'
```



```

Holweger-Mueller-Atmosphere, from 1974
uio-form:                13-Nov-1996 18:29:52
conversion type added: 20-Feb-1997 18:21:01
xi -> vmicro:           20-Feb-1997 18:23:43

real teff f=F6.1 b=4 n='effective temperature' u=K texa='T_eff'
5780.0

table atmosphere d=(1:7,1:29) f=X b=1 n=Holweger-Mueller-Atmosphere &
c0='Hartmut Holweger & Edith Mueller (1974) Solar Physics 39, 19-30, table II' &
c1=Teff(Sun)=5780K
real tauss f=E9.2 b=4 n='optical depth (Rosseland)' u=1
real tau5000 f=F7.3 b=4 n='optical depth (lambda5000)' u=1 t=log10
real t f=F7.0 b=4 n=temperature u=K
real pgas f=F6.3 b=4 n='gas pressure' u=dyn/cm^2
real pel f=F6.3 b=4 n='electron pressure' u=dyn/cm^2
real vmicro f=F4.2 b=4 n=microturbulence u=km/s
real q f=F8.5 b=4 n='Hopf function' u=1 c0='q=((T(tau)/Teff)^4)/0.75)-tau'
  tauss tau5000 t pgas pel vmic q
2.00E-07 -6.539 3900. 0.769 -3.140 0.00 0.27637
2.50E-07 -6.279 3920. 1.171 -2.752 0.00 0.28208
5.00E-07 -5.868 3970. 1.598 -2.342 0.00 0.29675
1.00E-06 -5.588 4030. 1.842 -2.105 0.00 0.31510
2.00E-06 -5.334 4080. 2.042 -1.910 0.00 0.33103
5.00E-06 -5.001 4160. 2.279 -1.674 0.00 0.35776
1.00E-05 -4.747 4210. 2.450 -1.508 0.00 0.37527
2.00E-05 -4.486 4270. 2.618 -1.341 0.00 0.39712
5.00E-05 -4.131 4340. 2.835 -1.128 0.00 0.42377
1.00E-04 -3.856 4400. 2.999 -0.967 0.50 0.44765
2.00E-04 -3.577 4460. 3.162 -0.804 0.50 0.47248
5.00E-04 -3.200 4530. 3.377 -0.596 0.50 0.50256
1.00E-03 -2.912 4590. 3.541 -0.437 0.50 0.52925
2.00E-03 -2.621 4640. 3.704 -0.279 0.50 0.55173
5.00E-03 -2.233 4720. 3.919 -0.070 0.50 0.58792
1.00E-02 -1.939 4800. 4.083 0.094 0.50 0.62415
2.00E-02 -1.645 4900. 4.245 0.266 0.65 0.66867
5.00E-02 -1.256 5080. 4.460 0.504 0.85 0.74558
1.00E-01 -0.961 5260. 4.622 0.705 1.00 0.81447
2.50E-01 -0.571 5560. 4.830 1.002 1.25 0.89163
4.00E-01 -0.371 5850. 4.926 1.251 1.40 0.99911
7.00E-01 -0.133 6260. 5.022 1.613 1.50 1.13453
1.00E+00 0.019 6570. 5.070 1.879 1.60 1.22581
1.50E+00 0.191 6880. 5.114 2.140 1.70 1.17659
2.00E+00 0.312 7160. 5.140 2.363 1.80 1.13964
4.00E+00 0.597 7920. 5.191 2.889 1.80 0.70033
6.00E+00 0.761 8250. 5.213 3.092 1.80 -0.46595
8.00E+00 0.877 8420. 5.229 3.196 1.80 -1.99552
1.00E+01 0.967 8500. 5.242 3.245 1.80 -3.76404

```

#### 4.3.4 Recommendations for Standard File Structure

The very first entry in an UIO file is always the `fileform` `uio` entry, containing information about the file format and conversion type. Afterwards, entries can follow in any order. But it is perhaps a good idea to start the file with three special entries (`file_id`, `description`, `history`) as in

```
fileform uio form=formatted convert=ieee_4 ...
```

```
character file_id f=A80 b=80 n='File identification'
uio-demofile
```

```
character description d=(1:2) f=A80 p=1 b=80 n='File description'
This is a file to demonstrate the recommended start entries for all
UIO files.
```

```
character history d=(1:1) f=A80 p=1 b=80 n='File history'
UIO demo file: 22-Dec-1997 14:15:15
```

A recommended format for sets of multi-dimensional arrays (e.g. hydrodynamics: x-axis, y-axis, z-axis, density, velocities, energy, ...) is shown in Sect. 5.1.

## 4.4 Files & Directories & Paths

All UIO-routines are located in subdirectories of a common directory (called e.g. `uio`), which also contains a Readme file. The subdirectories and their contents are

```
bin      : shell scripts: uiolook, uiocat, uioinfo
f90      : Fortran90 source codes, object files, executables
idl      : IDL routines
man/man1: manual pages for shell scripts: uiolook, uiocat, uioinfo
tex      : old description files in LATEX, the most recent version is part of this document
```

To use the UNIX scripts and the makefile you need a global system variable **UIOPATH** pointing to this directory. The path to the shell scripts and to the man-pages should be added to your shell path variables e.g. in one of the login scripts:

C-shell (`.cshrc`):

```
# --- uio ---
setenv UIOPATH "$HOME/uio"
setenv PATH "$PATH:$UIOPATH/bin"
setenv MANPATH "$MANPATH:$UIOPATH/man"
# --- *** ---
```

Korn-shell (`.kshrc`):

```
# --- uio ---
UIOPATH=$HOME/uio
export UIOPATH
PATH=$PATH:$UIOPATH/bin
export PATH
MANPATH=$MANPATH:$UIOPATH/man
export MANPATH
# --- *** ---
```

## 4.5 Fortran90

### 4.5.1 Files

The Fortran UIO package is a collection of Fortran90 modules and programs described in Table 8.

The file `uio_base_module.f90` contains the basic set of modules (see Table 9).

The files `uio_mac*_module.f90` (Tab. 8) contain machine dependent routines collected in the module `uio_mac_module` (see Tab. 10).

It comes in various flavors. The machine-independent version is `uio_mac_module.f90` which can be used for first tests but does not provide all possible features. Therefore, it should be discarded afterwards and replaced by a version more suitable for the platform in use. The file `uio_mac_ieee_module.f90` is appropriate for all machines with IEEE `big_endian` binary format. Additionally there exist files containing calls of machine library routines

File	contents
<code>uio_base_module.f90</code>	Collection of basic modules
<code>uio_mac_module.f90</code>	(Possibly) machine dependent routines Standard version (all machines)
<code>uio_mac_ieee_module.f90</code>	Machine dependent routines: IEEE format
<code>uio_mac_sun_module.f90</code>	Machine dependent routines: Sun, SGI, Linux, HP
<code>uio_mac_intel_module.f90</code>	Machine dependent routines: Linux Intel ( <code>little_endian</code> )
<code>uio_mac_crayts_module.f90</code>	Machine dependent routines: CRAY
<code>uio_mac_crayxmp_module.f90</code>	Machine dependent routines: CRAY
<code>uio_mac_decalpha_module.f90</code>	Machine dependent routines: alpha
<code>uio_mac_hitachi_module.f90</code>	Machine dependent routines: Hitachi
<code>uio_bulk_module.f90</code>	Main part of UIO routines
<code>uio_filedef_module.f90</code>	Standard file descriptors and labels
<code>uio_table_module.f90</code>	Table manipulation routines
<code>uio_var_module.f90</code>	definition and handling of UIO flexible variable
<code>uio_varfile_module.f90</code>	definition and handling of file structure of UIO flexible variables
<code>uiocop.f90</code>	Program to copy and transform UIO files
<code>uiolok.f90</code>	Program to look into UIO files
<code>uioinf.f90</code>	Program to give information about conversion types
<code>uiotst.f90</code>	Program to produce test UIO file

Table 8: UIO Fortran90 files

module	contents
<code>uio_cst_module</code>	channel status information
<code>uio_cvl_module</code>	convert type list of current machine
<code>uio_inf_module</code>	information about environment
<code>uio_nam_module</code>	definition of names
<code>uio_siz_module</code>	string length, table size
<code>uio_base_module</code>	basic set of UIO-routines: string processing, header handling, I/O channel management

Table 9: Contents of `uio_base_module.f90`

`uio_mac_crayts_module.f90`, `uio_mac_crayxmp_module.f90`, `uio_mac_sun_module.f90`. These make it possible to write information about the platform in use into the file header. The CRAY versions allow unformatted I/O in the CRAY specific format and additionally (via the FFIO ASSIGN logic) in IEEE format. The file `uio_mac_intel_module.f90` is appropriate for all machines with IEEE `little_endian` binary format (and no mechanism for automatic conversion).

The main set of routines is contained in `uio_bulk_module.f90` in the module `uio_bulk_module`.

The three files `uio_base_module.f90`, `uio_mac_module.f90`, and `uio_bulk_module.f90` comprise the standard set of UIO routines.

Additionally there exists a file `uio_table_module.f90` with the single module `uio.table_module` which permits the I/O and manipulation of a certain table format (see the example in section 4.2).

The latest extension comes within the modules `uio_var_module.f90` and `uio_varfile_module.f90`. The module `uio_var_module.f90` contains a type definition for a variable (“uio flexible variable”) of general type (i.e. it may be a scalar integer value or a 1D character array or a 3D real array...) together with some routines for the basic handling of the variables (I/O in UIO format, construction and modification of variables...). The module

routine	purpose
uio_getenv	Get information about environment
uio_mkcvls	Make list with possible conversion types
uio_uopen	Open file with special handling for conversion type
uio_uclose	Close file with special handling for conversion type

Table 10: Contents of uio\_mac\_module

uio\_varfile\_module.f90 contains a type definition for a file built of UIO flexible variables together with routines for the handling of these files.

#### 4.5.2 Use of UIO Modules in Fortran90

To make the UIO routines available in a Fortran program the appropriate modules have to be specified in a `USE` statement.

At maximum five modules play a role: The `uio_bulk_module` contains the main part of the UIO routines (and also uses the relevant sub-modules). Instead of `uio_bulk_module` the module `uio_table_module` is used if the UIO table routines are needed. The modules `uio_siz_module` and `uio_nam_module` contain specifications about the size of some arrays and the length of strings, and the names of types and keywords, respectively. The module `uio_filedef_module` contains some definitions in addition to the basic UIO standard as e.g. the label names which delimit a data set (`label dataset` and `label enddataset`).

A typical case for the use of UIO modules is

```
use uio_bulk_module
use uio_siz_module
use uio_nam_module
```

#### 4.5.3 Compiling and Makefiles

There is a Makefile for the UIO routines. For a certain platform it is necessary to change the name of the module file with the machine dependent routines (`uio_mac*_module.f90`). For this purpose the environment variable `UIOMAC` has to set to name of the appropriate routine (see Sect. 3.3). Many compilers generate module information files with suffixes like `.M`, `.mod`, or `.kmo`. To clean up information files with other suffixes, they have to be included in the cleaning step.

Calling examples:

```
make
make UIO
make UIO "F90FLAGS=-g"
make clean
make cleanall
make remove
make removeall
```

A section of a typical makefile using the UIO routines may be

```
...
# --- Compiler options ---
F90C=f90
F90FLAGS=
# --- Libraries ---
UIOMAC=uio_mac_sun_module
...
```

```
# --- Dependencies of exe-files on object files and libraries ---
test.exe: test.o
        $(F90C) $(F90FLAGS) -o $@          $(UIOPATH)/f90/uio_base_module.o $(UIOPATH)/f90

test.o: $(UIOPATH)/f90/UIO test.f90
        $(F90C) -c $(F90FLAGS)          -M$(UIOPATH)/f90          test.f90
...
# --- Dependencies on used modules ---
$(UIOPATH)/f90/UIO:
        cd $(UIOPATH)/f90 ; make UIO "F90FLAGS=$(F90FLAGS)"
```

#### 4.5.4 Sample Calls of Fortran UIO Routines

The needed modules have to be declared by a `use` statement like:

```
use uio_bulk_module
```

In the initial phase of the program the UIO routine package has to be initialized by exactly one call of the `uio_init` routine with the name of the program as optional parameter:

```
call uio_init(program='uiotst')
```

The internal list of logical I/O unit numbers may be changed with calls of `uio_chunit` and `uio_chconv`.

A file can be opened for writing with

```
file='test.txt'
form='formatted' ! or: 'unformatted'
conv='ieee_4'    ! or: 'native', 'crayxmp_8',...
call uio_openwr(ncout, file, form=form,conv=conv)
```

Header and data block are written together with one command as e.g. in:

```
call uio_wr(ncout, time,      'time', name='time',  unit='s'      )
call uio_wr(ncout, rho(1:10), 'rho',  name='density', unit='g/cm^3')
```

There are two different routines to close a file after reading or writing. A file opened for writing is closed by:

```
call uio_closwr(ncout)
```

To open a file for reading, only the file name has to be specified. File form and conversion type are determined automatically:

```
file='test.txt'
call uio_openrd(ncin, file)
```

In contrast to the writing of an entry by one routine call the reading is performed in two separate sub-steps for the header and the data part. After the reading of the header e.g. with

```
use uio_siz_module
use uio_nam_module
...
integer                                :: ntt
character*(let)                         :: termt(2,nttmx)
...
call uio_rdhd(ncin, termt,ntt)
```

the identifier, type, and dimension (if any) of the entry is contained in the character array `termt` with `ntt` entries and special actions may be taken: The data part may be skipped with

```
uio_skipda(ncin, termt,ntt)
```

or it can be read with:

```
call uio_rd(ncin, termt,ntt, time, ident)
```

If the entry is an array it may be necessary to allocate memory:

```
call uio_exkeyw(termt,ntt, dimna,dimstr)
call uio_st2dim(dimstr, ilow, iup, ndim=ndim)
allocate(rho(ilow(1):iup(1)))
call uio_rd(ncin, termt,ntt, rho, ident, ilb=ilow(1:1))
```

Alternatively, it is possible to search in the file for a special entry or to search in a specially generated entry list with:

```
call uio_srhdc(ncin, termt,ntt, type='real',ident='rho',outstr=outstr,ierr=ierr)
```

Additionally, the module `uio_var_module` makes it possible to read any entry into an UIO flexible variable, and the module `uio_varfile_module` allows the reading of a complete file into a special file structure of UIO flexible variables.

To close file after reading use

```
uio_closrd(ncin)
```

There are several examples of programs with UIO routines like `uio_var_test.f90`, `uio_varfile_test.f90`, `uiotst.f90`, (`uio_demo.f90`).

## 4.6 UNIX Scripts

So far, there exist three UNIX shell scripts useful to quickly examine data sets (`uiolook`), to change the format or conversion type of files (`uiocat`), or to print some information about the conversion types possible on the local machine (`uioinfo`).

### 4.6.1 Quick Examination of Files: `uiolook`

The shell script `uiolook` calls the Fortran program `uiolok.f90`. The man-page:

```
UIOLOOK(1V)          Misc. Reference Manual Pages          UIOLOOK(1V)
```

#### NAME

```
    uiolook - print entry headers of file in uio form
```

#### SYNOPSIS

```
    uiolook [ -h ] [ -p ] [ filename ... ]
```

#### AVAILABILITY

#### DESCRIPTION

```
    The routine uiolook reads each filename (file in uio form)
    in sequence and displays the headers of the entries in
    pretty form.
```

#### OPTIONS

```
    -h    Print usage of uiolook.

    -p    Entry header keywords in (long) pretty form
```

### 4.6.2 Transformation of Files: uiocat

The shell script uiocat calls the Fortran program uiocat.f90. The man-page:

UIOCAT(1V)            Misc. Reference Manual Pages            UIOCAT(1V)

#### NAME

uiocat - concatenate file(s) in uio form

#### SYNOPSIS

```
uiocat [ -c conversion ] [ -f format ] [ -h ] [ -l copylist
] [ -o outputfilename ] [ filename ... ]
```

#### DESCRIPTION

The routine uiocat reads each filename (file in uio form) in sequence and displays its contents formatted on standard output or writes it into a file. In the latter case the format change from 'formatted' to 'unformatted' or vice versa is possible.

#### OPTIONS

- c Conversion type: 'native', 'ieee\_4', ... (machine dependent), its specification is only relevant, if an output file is specified with the -o option and output format='unformatted'.
- f Output format: 'formatted' or 'unformatted'. Its specification is only relevant, if an output file is specified with the -o option.
- h Help: print usage of uiocat.
- l List of entries to be copied. E.g.
 

```
uiocat ... -l"real rho"
uiocat ... -l"real rho,integer i"
uiocat ... -l"label *,real rho,integer i"
uiocat ... -l"label *,real rho,* i"
```

 Here, copylist is a list, separated by ",". Each item consists of exactly two items, separated by a blank. No additional blanks are allowed. Use copylist with "" as above.
- o Output file name. If omitted, standard output is used and "-c" and "-f" are meaningless.

SunOS 5.5.1            Last change: 12 January 1998            1

### 4.6.3 Information about Conversion Types: uioinfo

The shell script uioinfo calls the Fortran program uioinf.f90. The man-page:

uioinfo(1V)            Misc. Reference Manual Pages            uioinfo(1V)

#### NAME

uioinfo - print machine dependent information

#### SYNOPSIS

```
uioinfo
```

#### DESCRIPTION

The routine uioinfo prints information about its environment

and a list of possible conversion types.

#### OPTIONS

SunOS 5.5.1

Last change: 12 January 1998

1

### 4.7 IDL UIO Routines

The UIO package in IDL comes as a list of routines with names quite similar to the Fortran90 version. Instead of using global variables as in Fortran90 there are now common blocks in Include-files.

```

;*****
; Routines, functions : uio_*.pro:
;
;      (!: most important, +: user-routine, -: comfortable, .:useful)
; . adkey1:      Add one keyword to term table, keyword-value=' ', no link character
; . adkey2:      Add one keyword to term table with keyword-value
; . adkey3:      Add one keyword to term table with keyword-value or default
; . chconv:      Actualize list of conversion types for all channels
; + chpos:       Give current file position or jump to specified position
; . chunit:      Initialize, store and actualize a list of free and occupied unit
;                numbers
; + closrd:      Close file after reading
; + closwr:      Close file after writing
; - cpentr:      Copy entry from one file to another
; + d:           Read data from uio-file(s) in quasi direct access mode
; + data:        Handle uio-file(s) in quasi direct access mode
; ! dataset_rd:  Read uio file and put data into anonymous structure
; ! uio_datasetlist_rd: Read data from list of files and put it into an. structure
; deform:       Determine the default output format for numbers
; dim2st:       Compose dimension string
; . exkeyw:      Extract value of keyword from table
; exlrm:        Extract one term from the input line
; exmtrm:       Transform a list of items into its components
; . filcon:      Determine file contents: list of all entries with its positions
; getenv:       Get information about environment
; ! init:       Initialization procedure for input/output routines
; melrm:        Merge the input term: 'keyword', 'value' -> 'keyword=value'
; memtrm:       Merge a list of terms (keywords and their values) into a line table
; mkcvs:        Make list with possible conversion types
; . nc2nt:      From column number or entry name find table entry number
; + openrd:     Open file for reading, read header
; + openwr:     Open file for writing, write header
; - pptrmt:     Print term table in pretty form
; qmaadd:       Transform a string into a string with quotation marks if necessary
; qmadel:       Parse string "inline" and remove quotation marks if necessary
; + rd:         Reading scalar and array data of all types
; . rdfifo:     Read file header
; + rdhdex:     Read header of variable and extract keywords
; rdhead:       Read header
; + rdlabl:     Read label
; + rdtab:      Read table of integer, real, and/or character data from file
; + skipda:     Skip data block
; - slhdex:     Search header of variables given by list and extract keywords
; . st2dim:     Parse dimension string
; ! struct_rd:  Read uio file and put data into anonymous structure
; . tab0:       Create empty table structure
; + tabc:       Change and modify table contents: rearrange lines.
; + tabm:       Merge two tables in different ways
; + tabr:       Read 1d array from 2d table array (all types)

```



```

; + tabw:      Write 1d array into table (all types)
; uclose:     Close file with special handling for conversion type
; uopen:      Open file with special handling for conversion type
; vnanrm:     Transform a string to give a correct name of a variable
; wf2rf:      Produce from write format string corresponding read format string
; + wr:       Writing scalar and array data of all types
; . wrfifo:   Write file header
; wrhdme:     Write header of variable, input: term table.
; wrhead:     Write header of variable, input: line table.
; + wrlabl:   Write label
; + wrtab:    Write table of integer, real, and/or character data to file
;*****
; Include-Files uio_*.pro:
; filedefinc:
; uiocstinc:  channel status information (common uio_chainf)
; uiocvlinc:  convert type list of current machine (common uio_cvlist)
; uionaminc:  names of types, keywords, identifiers; default formats
;             (common uio_defnam)
; uiosizinc:  length of strings, size of tables (trmtab, lintab)
; uiotabinc:  empty table structure (common uio_taborg)
;*****

```

Most of the routines are low-level ones and do not have to be worried about because they rarely will be used directly.

For accessing data in UIO format within IDL the initialization routine `uio_init` (see Sect. 4.7.1) and the high-level reading routines (`uio_struct_rd.pro`, `uio_dataset_rd.pro`, and `uio_datasetlist_rd.pro`, see Sect. 4.7.3). might suffice.

#### 4.7.1 Initialization of UIO Routines under IDL

The directory containing the IDL UIO routines should be added to the IDL variable `!PATH`. This could be done by a program segment in the startup procedure, like:

```

; --- Try to determine language ---
if (n_elements(!X.TICKV) eq 150) then langua='WAVE' else langua='IDL'
;
; --- Add user IDL directory to search path ---
if (langua eq 'IDL') then begin &$
  addpath=expand_path('+$UIOPATH/idl') &$
endif else begin &$
  addpath='/home/supas024/uio/idl' + ':' + '/home/supas024/wave' &$
endelse
if strtrim(addpath,2) ne '' then !path=addpath+':'+!path
delvar, addpath

```

Alternatively, one might want to set the IDL path variable accordingly like

```
export IDL_PATH="+$UIOPATH/idl"
```

for example in the `.bashrc` file.

It is reasonable to include the UIO initialization in the startup procedure as e.g.:

```

; --- Initialize uio-routines ---
uio_init, progrm='by hand'

```

IDL can handle the conversion types `native`, `ieee_4`, `ieeele_4`, `ieee`, `idl`, `xdr` (compare Tab. 5 in Sect 4.3.1). Here, `ieee_4` is the default and should be used as a standard.

**Attention:** The IDL type “long” corresponds to the standard Fortran type “integer”. The IDL types “byte” and “integer” are not known in standard Fortran and are therefore transformed to the IDL type “long” before writing (in the IDL routine `uio_wr`).

**Be aware of:** The parsing and interpretation of the entry headers can only be done by scalar operations which are comparatively slow in IDL.

### 4.7.2 Reading Data with `uio_data.pro`

The IDL routine `uio_data` and the IDL function `uio_d` were the first set of “high-level” routines to read UIO data in IDL. They were useful for the easy reading of not too complex data files. By now, they are replaced by the routines `uio_struct_rd` and `uio_dataset_rd` (see see next Section and Sect 7).

The old routines allow the opening,

```
uio_data, mode='open', filename='model.dat'
uio_data, mode='open', filename='model*.txt'
uio_data, mode='open', filename='model.dat', family='mod1'
uio_data, mode='open', filename='model*.txt', family='mod2'
```

examination,

```
uio_data, mode='content'
uio_data, mode='files'
```

reading,

```
uio_data, mode='read', value=rho, 'rho'
uio_data, value=temp, 'temp'
uio_data, value=p, 'p', filename='model.dat'
uio_data, value=p, 'p', family='mod1'
plot_oi, uio_d('p'), uio_d('t')
```

and closing,

```
uio_data, mode='close', filename='model.dat'
uio_data, mode='close', filename='model*.txt'
uio_data, mode='close', family='mod2'
uio_data, mode='allclose'
```

of UIO files.

### 4.7.3 Reading Data with `uio_dataset_rd.pro` or `uio_datasetlist_rd.pro`

For a detailed description of how to handle UIO files in IDL see Sect 7.

With the new IDL routines `uio_struct_rd.pro`, `uio_dataset_rd.pro`, and `uio_datasetlist_rd.pro` files are not read entry by entry anymore but in larger blocks (or “data sets”).

With `uio_struct_rd` all entries in a file are read and put into an IDL structure variable. This is appropriate for the CO5BOLD parameter file or for the UIO table file in Sect. 4.3.3, e.g.

```
par=uio_struct_rd('st35gm04n05_03.par')
atm=uio_struct_rd('holmu.atm')
```

When groups of entries in an UIO file are properly marked with `label dataset` and `label enddataset` delimiters (confer the example in Sect. 5.1) each group can be accessed with `uio_dataset_rd`. The first block can be read with

```
ful=uio_dataset_rd('st35gm04n05_03.full')
```

or

```
ful=uio_dataset_rd('st35gm04n05_03.full', ndataset=0)
```

Dataset number `i+1` (counting starts at zero) can be read with

```
ful=uio_dataset_rd('st35gm04n05_03.full', ndataset=i)
```

If a dataset with that number does not exist, an empty structure is returned. In this case, when called with additional keywords like

```
ful=uiio_dataset_rd('st35gm04n05_03.full', ndataset=i, outstr=outstr,ierr=ierr)
```

an error message is returned in `outstr` and `ierr` is set to a value larger than 0.

To read all entries in a list of files in sequence the routine `uiio_datasetlist_rd.pro` is convenient, as in

```
model='st33gm06n03' & modelident='_??' & parmodelident='_01'
modeldisk=getenv('HOME') + '/dat/rhd/d' + model + '/'
;
modelfile=modeldisk + model + modelident + '.full'
parfile =modeldisk + model + parmodelident + '.par'
;
; --- Read parameter file ---
par=uiio_struct_rd(parfile)
;
; --- Open first dataset to get some information about array sizes ---
delvar, listdata
ful=uiio_datasetlist_rd(modelfile, listdata=listdata, ierr=ierr)
uiio_closrd, listdata.channel
delvar, listdata
;
nxc1=n_elements(ful.z.xc1)
nxc2=n_elements(ful.z.xc2)
nxc3=n_elements(ful.z.xc3)
;
n_timestep=1000 ; --- Some huge value to get everything. Reduce for tests! ---
ierr=0
i=0
;
; --- Loop over all datasets ---
while ((ierr eq 0) and (i lt n_timestep)) do begin &$
  ; --- Read the next dataset ---
  ful=uiio_datasetlist_rd(modelfile, listdata=listdata, ierr=ierr) &$
  if (ierr eq 0) then begin &$
    print, '--- ', i, ful.z.itime, ful.z.time, format='(A,I4,I6,E15.8)' &$
    ;
    ; --- Now do the data handling (demo) ---
    print, 'Mean density: ', avg(ful.z.rho) &$
    ;
    i=i+1 &$
  endif &$
endwhile
```

Note that you can specify an entire group of files with `modelident='_??'`.

## 5 Control and Data Files

Table 11 shows a list of all files necessary to run CO5BOLD. Figure 3 gives similar information but is not quite up to date. Executing the makefile produces an executable `rhd.exe`. Its name can of course be changed afterwards. The names of the three control files `rhd.par`, `rhd.stop`, and `rhd.cont` and of the status file `rhd.done` cannot be changed (without modification of the source code). The names of EOS, opacity, and CO5BOLD data files can be chosen freely in the parameter file `rhd.par`. Table 11 only contains dummy names.

File	Sect.	I/O	Type	Description
<code>rhd.exe</code>	3.2		executable	main program
<code>rhd.par</code>	5.3	I	control/data: UIO	central control file
<code>rhd.stop</code>	5.4	I	control	file to force controlled stop of simulation
<code>rhd.cont</code>	5.4	I	control	file to force continuation after stop
<code>data.eos</code>		I	data: UIO	tabulated equation of state
<code>data.opta</code>		I	data	tabulated opacities
<code>rhd.sta</code>	5.1	I	data: UIO	start model (e.g. end file of last run)
<code>rhd.done</code>	5.4	O	status	exit status: written if run was successful
<code>rhd.end</code>	5.1	O	data: UIO	end model
<code>rhd.full</code>	5.1	O	data: UIO	sequence of (2D or 3D) snapshots, large
<code>rhd.mean</code>	5.2	O	data: UIO	derived data: mean flux, intensity
<code>rhd.out</code>	5.5	O	data: text	human readable text output

Table 11: List of all control and data files of CO5BOLD

### 5.1 Model Files: `rhd.sta`, `rhd.end`, `rhd.full`

If the UIO scripts (Sect. 4.6) are properly installed, you can view the contents (more precisely the headers of the data entries) of an UIO file with `uiolook filename`, e.g.

```
uiolook st35gm04n05_03.end
```

gives the output (slightly edited)

```
fileform uio form=unformatted convert=ieee_4 version=0.1.2000.11.26 &
  date='02.01.2002 16:17:26.036' system=craSHi machine=craSHi osrelease=10.0.0.6 &
  osversion=UoK.4 hardware='CRAY SV1' language=Fortran90 program=RHD
```

```
character file_id f=A8 b=8 n='File identification'
character description d=(1:1) f=A24 p=1 b=24 n='File description'
character history d=(1:20) f=A80 p=1 b=80 n='File history'
character version f=A80 b=80 n='Program version'
```

```
label dataset n='RHD model' date='02.01.2002 16:17:26.043'
  character dataset_id f=A10 b=10 n='Type of box hierarchy'
  real modeltime f=E13.6 b=4 n=time u=s
  integer modelitime f=I11 b=4 n='time step number' u=1
  real dtime f=E13.6 b=4 n='time step' u=s
  real time_out_full_last f=E13.6 b=4 n='Time of last output of full model' u=s
  real time_out_mean_last f=E13.6 b=4 n='Time of last output of averaged data' &
  u=s
```

```
label box date='02.01.2002 16:17:26.049'
  character box_id f=A80 b=80 n='Block identification'
  integer dimension d=(1:2,1:3) f=I7 p=6 b=4
  real time f=E13.6 b=4 n=time u=s
  integer itime f=I11 b=4 n='time step number' u=1
  real xc1 d=(-63:63,-63:-63,-63:-63) f=E13.6 p=4 b=4 &
```

```

n='x1 coordinates of cell centers' u=cm ds=(0:0,0:1,0:1)
real xc2 d=(-63:-63,-63:63,-63:-63) f=E13.6 p=4 b=4 &
  n='x2 coordinates of cell centers' u=cm ds=(0:1,0:0,0:1)
real xc3 d=(-63:-63,-63:-63,-63:63) f=E13.6 p=4 b=4 &
  n='x3 coordinates of cell centers' u=cm ds=(0:1,0:1,0:0)
real xb1 d=(-63:64,-63:-63,-63:-63) f=E13.6 p=4 b=4 &
  n='x1 coordinates of cell boundaries' u=cm ds=(0:1,0:1,0:1)
real xb2 d=(-63:-63,-63:64,-63:-63) f=E13.6 p=4 b=4 &
  n='x2 coordinates of cell boundaries' u=cm ds=(0:1,0:1,0:1)
real xb3 d=(-63:-63,-63:-63,-63:64) f=E13.6 p=4 b=4 &
  n='x3 coordinates of cell boundaries' u=cm ds=(0:1,0:1,0:1)
real rho d=(-63:63,-63:63,-63:63) f=E13.6 p=4 b=4 n=Density u=g/cm^3
real ei d=(-63:63,-63:63,-63:63) f=E13.6 p=4 b=4 n='Internal energy' u=erg/g
real v1 d=(-63:63,-63:63,-63:63) f=E13.6 p=4 b=4 n='Velocity 1' u=cm/s
real v2 d=(-63:63,-63:63,-63:63) f=E13.6 p=4 b=4 n='Velocity 2' u=cm/s
real v3 d=(-63:63,-63:63,-63:63) f=E13.6 p=4 b=4 n='Velocity 3' u=cm/s
label endbox
label enddataset date='02.01.2002 16:17:43.322'

```

The UIO format is described in some detail in Sect 4. Each entry has a type (e.g. “label”, “real”, “character”), an identifier (e.g. “box”, “time”, “description”), and additional information about array size (e.g. “d=(-63:63,-63:63,-63:63)”), data format (e.g. “f=E13.6 p=4 b=4”), and properties of the quantity (e.g. “n=Density u=g/cm<sup>3</sup>”).

Each start (“rhd.sta”) or final (“rhd.end”) model file has a structure as shown above. The (“rhd.full”) file usually contains a sequence of these data sets, which of course can also be used as start model of a simulation.

The axes `xc1`, `xc2`, and `xc3` describe the positions of the cell centers. The axes `xb1`, `xb2`, and `xb3` contain the positions of the cell boundaries: they have one element more than the corresponding cell centered quantity.

Cell boundaries should be centered in the middle between cell centers for the best representation of radiative fluxes with MSrad3D.

## 5.2 File with Additional Data: rhd.mean

A “rhd.mean” file contains derived data (averaged fluxes, other averaged quantities, surface intensities) in addition to the complete data sets in “rhd.full” files. It has more entries than a full model file. However, they are much smaller. Therefore, one can afford a higher output sampling rate.

Its format is usually Fortran “unformatted” (binary).

### 5.2.1 Organization of rhd.mean File

A mean file usually consists of several datasets. The overall structure is

```

fileform uio form=unformatted convert=ieee_4

character file_id f=A8 b=8 n='File identification'
character description d=(1:1) f=A14 p=2 b=14 n='File description'
character history d=(1:20) f=A80 p=1 b=80 n='File history'
character version f=A80 b=80 n='Program version'

label dataset n='RHD model'
...
label enddataset

label dataset n='RHD model'
...
label enddataset
.

```

.  
.

Each dataset has the following structure (for a supergiant simulation):

```
label dataset n='RHD model' date='25.05.2001 09:41:29.405'
...
```

```
label box date='25.05.2001 09:41:29.408'
character box_id f=A80 b=80 n='Block identification'
rad
...
label endbox
```

```
label box date='25.05.2001 09:41:29.983'
character box_id f=A2 b=2 n='Block identification'
z1
...
label endbox
```

```
label box date='25.05.2001 09:41:30.078'
character box_id f=A2 b=2 n='Block identification'
z2
...
label endbox
```

```
label box date='25.05.2001 09:41:30.170'
character box_id f=A2 b=2 n='Block identification'
z3
...
label endbox
```

```
label box date='25.05.2001 09:41:30.260'
character box_id f=A1 b=1 n='Block identification'
r
...
label endbox
```

```
label box date='25.05.2001 09:41:30.359'
character box_id f=A80 b=80 n='Block identification'
z
...
label endbox
label enddataset date='25.05.2001 09:41:30.489'
```

There are six sub-blocks delimited with `box` and `endbox` labels. They contain surface intensity and flux arrays (`rad`), averages in the 23-plane (`z1`), the 13-plane (`z2`), the 12-plane (`z3`), and over spherical shells (`r`), and a 2D slice through the model (`z`).

### 5.2.2 Contents of Individual `rhds.mean` File Entry

An individual box inside a dataset entry in a mean file can have e.g. the following contents describing horizontal averages in a plane-parallel model. With

```
uiolook chro2D03co08_01.mean | less
```

you get this (and more):

```
label box date='06.11.2002 17:58:05.533'
  character box_id f=A2 b=2 n='Block identification'
integer dimension d=(1:2,1:3) f=I7 p=6 b=4
```



```

real bc1_xmean2 d=(1:1,1:1,1:120) f=E13.6 p=4 b=4 &
                                n='Magnetic field 1' &
                                u=G
real bc2_xmean2 d=(1:1,1:1,1:120) f=E13.6 p=4 b=4 &
                                n='Magnetic field 2' &
                                u=G
real bc3_xmean2 d=(1:1,1:1,1:120) f=E13.6 p=4 b=4 &
                                n='Magnetic field 3' &
                                u=G
real ei_xmean d=(1:1,1:1,1:120) f=E13.6 p=4 b=4 n='Internal energy' &
                                u=erg/g
real rhoei_xmean d=(1:1,1:1,1:120) f=E13.6 p=4 b=4 &
                                n='Internal energy' &
                                u=erg/cm^3
real rhoek_xmean d=(1:1,1:1,1:120) f=E13.6 p=4 b=4 &
                                n='Kinetic energy' &
                                u=erg/cm^3
real rhoeg_xmean d=(1:1,1:1,1:120) f=E13.6 p=4 b=4 &
                                n='Gravitational energy' &
                                u=erg/cm^3
real t_xmean d=(1:1,1:1,1:120) f=E13.6 p=4 b=4 n=Temperature &
                                u=K
real t_xmean4 d=(1:1,1:1,1:120) f=E13.6 p=4 b=4 n=Temperature &
                                u=K
real t_xmeankapparho d=(1:1,1:1,1:120) f=E13.6 p=4 b=4 &
                                n=Temperature &
                                u=K
real p_xmean d=(1:1,1:1,1:120) f=E13.6 p=4 b=4 n=Pressure &
                                u=dyn/cm^2
real s_xmean d=(1:1,1:1,1:120) f=E13.6 p=4 b=4 n=Entropy &
                                u=erg/K/g
real rhos_xmean d=(1:1,1:1,1:120) f=E13.6 p=4 b=4 &
                                n=Entropy &
                                u=erg/K/cm^3
real gamma1_xmean d=(1:1,1:1,1:120) f=E13.6 p=4 b=4 &
                                n='1st Adiabatic Coefficient' &
                                u=1
real gamma3_xmean d=(1:1,1:1,1:120) f=E13.6 p=4 b=4 &
                                n='3rd Adiabatic Coefficient' &
                                u=1
real delta_xmean d=(1:1,1:1,1:120) f=E13.6 p=4 b=4 &
                                n='Expansion coefficient' &
                                u=1
real kapparho_xmean d=(1:1,1:1,1:120) f=E13.6 p=4 b=4 &
                                n='Absorption Coefficient' &
                                u=1/cm
real quc001_xmean d=(1:1,1:1,1:120) f=E13.6 p=4 b=4 &
                                n='Number density of CO' &
                                u=1/cm^3
rreal rhovb_xmean d=(1:1,1:1,1:121) f=E13.6 p=4 b=4 &
                                n='Mass flux' &
                                u=g/cm^ &
                                ds=(0:0,0:0,0:1)
real frhov13b_xmean d=(1:1,1:1,1:121) f=E13.6 p=4 b=4 &
                                n='Momentum x1 flux x3 direction' &
                                u=erg/cm^3 &
                                ds=(0:0,0:0,0:1)
real frhov23b_xmean d=(1:1,1:1,1:121) f=E13.6 p=4 b=4 &
                                n='Momentum x2 flux x3 direction' &
                                u=erg/cm^3 &
                                ds=(0:0,0:0,0:1)

```



```

real frhov33b_xmean d=(1:1,1:1,1:121) f=E13.6 p=4 b=4 &
                                n='Momentum x3 flux x3 direction' &
                                u=erg/cm^3 &
                                ds=(0:0,0:0,0:1)
real feipb_xmean d=(1:1,1:1,1:121) f=E13.6 p=4 b=4 &
                                n='Enthalpy Flux' &
                                u=erg/cm^2/s &
                                ds=(0:0,0:0,0:1)
real fekb_xmean d=(1:1,1:1,1:121) f=E13.6 p=4 b=4 &
                                n='Kinetic Energy Flux' &
                                u=erg/cm^2/s &
                                ds=(0:0,0:0,0:1)
real fegb_xmean d=(1:1,1:1,1:121) f=E13.6 p=4 b=4 &
                                n='Gravitational Energy Flux' &
                                u=erg/cm^2/s &
                                ds=(0:0,0:0,0:1)
real fepb_xmean d=(1:1,1:1,1:121) f=E13.6 p=4 b=4 &
                                n='Pressure Energy Flux' &
                                u=erg/cm^2/s &
                                ds=(0:0,0:0,0:1)
real fevb_xmean d=(1:1,1:1,1:121) f=E13.6 p=4 b=4 &
                                n='Viscous Energy Flux' &
                                u=erg/cm^2/s &
                                ds=(0:0,0:0,0:1)
real ferb_xmean d=(1:1,1:1,1:121) f=E13.6 p=4 b=4 &
                                n='Radiative Energy Flux' &
                                u=erg/cm^2/s &
                                ds=(0:0,0:0,0:1)
label endbox

```

The above list was slightly edited (by adding blanks) to improve readability.

The identifier of an entry together with the name (`n='...'`) and the unit (`u='...'`) should give a first hint about the meaning of the quantity. The suffix `'_xmean'` indicates a simple average. The suffix `'_xmean2'` indicates the root-mean-square average (note: the simple average is not subtracted).

Some entries (e.g. `ferb_xmean`) have a hidden `b` in their name, have one element more (e.g. 121 instead of 120) than most of the others, and are characterized by the `ds` keyword (see Table 7). These quantities are located at the cell boundaries in contrast to the usual cell-centered quantities. Clearly, there are also two sets of axes (e.g. `xc3` and `xb3`) corresponding to the cell- or boundary-centered quantities.

Note: The total energy flux can be written as sum

```
feb_total = feipkgvrb = feipb+fekb+fegb+fevb+ferb .
```

The flux `fepb` is already part of `feipb`.

### 5.3 Parameter File: rhd.par

The parameter file `rhd.par` also has the UIO format. But it will be usually Fortran “formatted” (ASCII).

It contains a list of parameter entries. which are collected in groups to make it easier to find an entry. Otherwise, the order is arbitrary (except for the very first `fileform uio` entry). If there are more than one entry with the same name, the first occurrence will be used by CO5BOLD. But the doubling of entries is strongly discouraged because it will almost certainly lead to confusion at some time. In addition, the IDL routine to read the parameter file will fail with an error message.

Additional entries can be added if the names differ from the standard ones described below. These entries will be ignored by CO5BOLD but read by the IDL input routine. They can be used to provide comments, additional information about the model, or control parameters for further processing.

### 5.3.1 Quickstart: How to Make a Proper Parameter File

You will never write a new parameter file from scratch. Typically, you take an old file (e.g. the one controlling the simulation which produced the model which is used to start the new run) and edit it:

1. Take the parameter file corresponding to the model you want the new simulation to start with.
2. Most of the parameters should be already OK. E.g. most of the parameters controlling the boundaries do not have to be changed.
3. Write a brief description of the purpose of the planned simulation into the `character description` array. You might put a remark about the parent file of the parameter file under construction and the current date into the `character history` array (see Sect. 5.3.2).
4. Check/modify the name of start model and output files: `infile_start`, `outfile_end`, `outfile_full`, `outfile_mean`. On a system with batch queue this has not to be done in the parameter file itself but in the external command file (see Sect. 5.3.13).
5. Check/modify the fundamental parameters including boundary condition specifiers (see Sections 5.3.3 and 5.3.4, respectively)
  - effective temperature control (`s_inflow`, `teff`, `luminositypervolume`, `C_radHtautop`)
  - gravity (`grav_mode`, `grav`, `mass_star`, ...)
  - abundances (`eosfile`, `opafile`, check the paths!)
6. If the gravity of the new model (and therefore the characteristic time scale) significantly deviates from the old one, the time specifications controlling the output frequency (`dtime_out_full`, `dtime_out_mean`), the total length of the simulation (if specified as stellar time: `endtime`, `plustime`), and absolute boundaries/specifications for the time step (`dtime_min`, `dtime_min_stop`, `dtime_max`, `dtime_start`) have to be scaled. Look for parameters with units `u=s` (see Sections 5.3.12 and 5.3.13).
7. The rest of the parameters controls additional details. Most of the constants are specified in dimensionless form and keep their value in a class of related simulations. The previously used values will probably be reasonable for the new simulation, too.

Of course, a complete control of CO5BOLD is only possible after studying of the meaning of the parameters in detail (e.g. by reading the following pages) AND – unfortunately – an accompanying look into the source code itself.

### 5.3.2 Header

The header of the parameter file contains information about the file format and contents. The `description` array can be used to specify the goal of the simulation, special model characteristics, or important parameter changes compared to a previous or standard model. The history array may contain the predecessor of the parameter file to simplify a tracing of parameter changes.

- `fileform uio`:  
The header of the parameter file, e.g.

```
fileform uio form=formatted convert=ieee_4 date='01.01.2002' &
  program='by hand'
```

can be abbreviated to

```
fileform uio form=formatted convert=ieee_4
```

which indicates that the file is in UIO form and Fortran “formatted” (ASCII). The specification of the conversion type (“convert=ieee\_4”) is more relevant for unformatted files. These terms should not be changed. But it can be of interest to append e.g. the date of the last modification (e.g. “date=’01.01.2002’”).

- **character file\_id:**  
The file identification string

```
character file_id f=A80 b=80 n='File identification'
rhd-parameter
```

indicates the intended use of the file as parameter file for the RHD code CO5BOLD. Do not edit!

- **character description:**  
The header of the file can (should) contain a short description of the simulation, as in e.g.

```
character description d=(1:4) f=A80 p=1 b=80 n='File description'
Parameter file for RHD code:
Full size 3D Betelgeuse model: 5 M_Sun, 650 R_Sun
Start with st35gm04n03_09.end (127^3 -> 171^3)
Run with SHORTrad
```

This entry is optional (it can be omitted completely) but it is recommended to put at least some relevant keywords into this array. If you change the number of lines (between 1 and 20) you have to adjust the size specification (“d=(1:4)” in the example above).

- **character history:**  
The file history has a similar purpose as the previous entry. It can be used to keep information about the “parent” parameter file, as in

```
character history d=(1:2) f=A80 p=1 b=80 n='File history'
Taken from st35gm04n03_09.par
Last Modification:      01.01.2002
```

Its use is optional.

### 5.3.3 Fundamental Model Parameters

- **real teff:**  
The effective temperature is one of the basic model parameters and is specified e.g. with

```
real teff f=F13.3 b=4 n='Effective Temperature' u=K
3500.0
```

(for a relatively cool star). Note that the actual effective temperature can only be determined a posteriori and that the entropy of the instreaming entropy (see below) is more important than `teff` itself. In fact, `teff` is only used to control material properties at the outer boundary. Its value should be close to the expected effective temperature of the model.

- **character grav\_mod:**  
Gravity is another characteristic of a stellar atmosphere. The type (or geometry) of the external gravity field has to be specified e.g. with

```
character grav_mode f=A80 b=80 n='Type of gravity field' &
c0='constant/central'
central
```

Two values are possible so far:

- **constant:** In the standard “solar” case the constant gravity specified with `real grav` is directed downward in `x3` direction.
- **central:** For the “supergiant” case a central potential is assumed with an origin at `x=0`. The stellar mass as well as inner and outer smoothing radius have to be specified.
- **real grav:**  
In the case of a constant gravity the amount of the acceleration has to be specified with

```
real grav f=E15.8 b=4 n='Gravity' u=cm/s^2
27500.0
```

Setting this value to zero switches off gravity (oh wonder).

- **real mass\_star:**  
In the case of a central the mass (in cgs units) of the star has to be specified with

```
real mass_star f=E15.8 b=4 n='Stellar Mass' u=g
9.94500e+33
```

- **real r0\_grav:**  
To avoid the central singularity in a  $1/r$  potential it is smoothed in the center to give a central potential of  $1/r0\_grav$ , specified with

```
real r0_grav f=E15.8 b=4 n='Inner Smoothing Radius' u=cm
9.45833e+12
```

This parameter should always be non-zero for a central potential.

- **real r1\_grav:**  
The density in an atmosphere in hydrostatic equilibrium can decline to very low values. To artificially enlarge the pressure (and density) scale height in the outer layers of the star (the corners of the box) the gravity can be reduced by defining the potential at infinity to be  $1/r1\_grav$ , specified with

```
real r1_grav f=E15.8 b=4 n='Outer Smoothing Radius' u=cm &
c0='0.0: Not used'
11.35000e+13
```

Setting this parameter to zero gives the usual  $1/r$  behavior of the potential in the outer layers but also chooses another smoothing formula in the central part (where `real r0_grav` is relevant). But a value somewhat larger than the remotest corner of the box effectively cancels this artificial smoothing in the outer layers without changing the formula for the potential.

- **real r1\_rad:**  
For a “Star-in-a-Box” and particularly when only “simple” ray directions are allowed in the radiation transport step the temperature in the outer corners of the box tends to become very small. To artificially increase the effect of radiative heating the parameter `real r1_rad` can specify a radius beyond which only positive contributions of the radiative energy transport to the energy budget are taken into account. This ruins the conservativity of the code in these layers and should be applied only in very remote corners which are then considered only as sort of extended boundary region but not as part of the “real” model. The parameter can be specified e.g. with

```
real r1_rad f=E15.8 b=4 n='Outer radiation transport radius' u=cm &
c0='0.0: Not used'
8.00000e+13
```

A value of 0.0 (default) or below deactivates this feature.

### 5.3.4 Boundary Conditions

The boundary conditions at the six sides of the computational box cannot be specified independently. For the naming convention of the boundaries a gravitational acceleration in -x3 direction is assumed. Accordingly, there is a bottom, a top, and four side boundaries.

- **character side\_bound:**

The boundary condition at all four sides is given by e.g.

```
character side_bound  f=A80 b=80 n='side boundary conditions' &
  c0='closed, transmitting, periodic'
transmitting
```

Possible values are:

- **reflective:** closed wall, no gravity, no radiation
- **constant:** open boundary with constant extrapolation of all values, no gravity, no radiation
- **closed, closedtop:** closed wall, can handle gravity, open for outward radiation
- **closedbottom:** closed wall, handles gravity, radiation in diffusion approximation
- **periodic:** periodic boundaries for hydrodynamics and radiation
- **transmitting:** transmitting boundary for hydro and outward radiation

Any of these values can be specified. But in fact, not all of them are recognized by all modules. Therefore some parameters are for test purposes (e.g. shock calculations) only. In simulations of a solar-like star with the **MSrad** radiation transport module the side boundaries *have* to be **periodic**. In simulations of a red supergiant all boundaries (including the sides) will typically be **transmitting**. As an alternative, **closed** boundaries can be chosen in this case.

- **character top\_bound:**

The boundary condition at the top of the model is given by for instance

```
character top_bound  f=A80 b=80 n='top boundary conditions'
transmitting
```

Possible values are:

- **reflective:** closed wall, no gravity, no radiation
- **constant:** open boundary with constant extrapolation of all values, no gravity, no radiation
- **closed, closedtop:** closed wall, can handle gravity, open for outward radiation
- **periodic:** periodic boundaries for hydrodynamics and radiation
- **transmitting:** transmitting boundary for hydro and outward radiation

In almost every simulation of stellar convection a **transmitting** top boundary will be selected, the **closed** one is an alternative. The **periodic** condition is only recognized by the hydrodynamics routines and not by any radiation transport routine.

- **character bottom\_bound:**

The boundary condition at the bottom of the model is given for instance by

```
character bottom_bound f=A80 b=80 n='bottom boundary conditions' &
  c0=closedbottom
transmitting
```

Possible values are:

- **reflective**: closed wall, no gravity, no radiation
- **constant**: open boundary with constant extrapolation of all values, no gravity, no radiation
- **closed, closedtop**: closed wall, can handle gravity, open for outward radiation
- **closedbottom**: closed wall, handles gravity, radiation in diffusion approximation
- **periodic**: periodic boundaries for hydrodynamics and radiation
- **transmitting**: transmitting boundary for hydro and outward radiation. The parameters `real c_tchange`, `real c_tsurf`, and `real c_hptopfactor` have to be specified.
- **inoutflow**: "classical" open lower boundary for deep convection, gravity and radiation possible. The parameters `real s_inflow`, `real c_schange`, and `real c_pchange` have to be specified.

In simulations of a solar-like star with the MSrad radiation transport module the bottom boundary is typically of type "inoutflow". A supergiant simulation will have a transmitting lower boundary.

- **real luminositypervolume:**

The luminosity of a "Star-in-a-Box" can be set with this parameter. To avoid numbers that do not fit into a 4 Byte real the luminosity per volume has to be specified as e.g. in

```
real luminositypervolume f=E15.8 b=4 n='Luminosity per core volume' &
    u='erg/cm^3/s'
4.5E-02
```

Reference volume is  $4/3\pi r_{\text{grav}}^3$ . If this parameter is set to a value of 0.0 or below the entropy of the material within the core (defined by as all cells within radius `r0_grav`) is adjusted instead.

- **real s\_inflow:**

The entropy of the material streaming through an open boundary of type "inoutflow" into the model can be specified e.g. with

```
real s_inflow f=E15.8 b=4 n='Entropy of core material' &
    u=erg/K/g
3.25E+09
```

In the case of a **central** potential the entropy in a sphere with radius `r0_grav` is adjusted towards this entropy value. In both geometry (supergiant as well as solar) this value is very important as it finally (but indirectly) determines the luminosity and effective temperature of the star. A value of 0.0 (default) or below disables this energy input.

- **real c\_schange:**

The entropy `s_inflow` of the material in the bottom layer (solar case, **inoutflow** boundary condition) or the central region of the model (supergiant case) is not just set to the specified but adjusted towards it. The adjustment rate can be controlled with e.g.

```
real c_schange f=E15.8 b=4 &
    n='Rate of entropy change for open lower boundary' u=1
0.3
```

Guide values are

- 1.0: fast adjustment
- 0.3: typical value
- 0.1: slow adjustment
- <=0.0: not allowed

- **real c\_pchange:**  
The **inoutflow** boundary condition not only controls entropy and velocity but also the pressure in the bottom layers: It is locally adjusted towards the global average to damp out possible instabilities. The adjustment rate can be specified e.g. with

```
real c_pchange f=E15.8 b=4 &
  n='Rate of pressure change for open lower boundary' u=1
  1.0
```

- **real c\_tchange:**  
In the case of a **transmitting** upper or outer boundary the temperature of the material streaming into the model is adjusted with a rate given e.g. by

```
real c_tchange f=E15.8 b=4 &
  n='Rate of temperature change for open upper boundary' u=1
  0.3
```

- **real c\_tsurf:**  
In the case of a **transmitting** upper or outer boundary the temperature of the material streaming into the model is adjusted towards a temperature  $t_{\text{eff}} \cdot c_{\text{tsurf}}$ . This temperature can be specified as fraction of the effective temperature e.g. with

```
real c_tsurf f=E15.8 b=4 n='Temperature factor for open upper boundary' u=1
  0.62
```

The value depends on where the outer boundary is located relative to the photosphere: If the boundary lies at a point where the solar photospheric minimum temperature is located, it can be fairly small. If the boundary is far away from the photosphere of a red supergiant, the value can be even smaller. On the other hand, if the boundary lies somewhere within the solar chromosphere even values above 1.0 might be reasonable.

- **real c\_hptopfactor:**  
In the case of a **transmitting** upper or outer boundary the density stratification outside the model has to be extrapolated properly. Assumptions about this density affects the amount of mass flowing into the model. For the extrapolation it is assumed that the density scale  $H_\rho$  scales with the pressure scale height  $H_p$  as  $H_\rho = H_p / c_{\text{hptopfactor}}$ .

```
real c_hptopfactor f=E15.8 b=4 &
  n='Correction factor for surface pressure scale height' u=1
  0.8
```

Possible values are

- $C < 0.0$ : No effect (actually, a value of 1.0 is chosen).
  - $0.0 \leq C < 1.0$ : The density scale height is enlarged to account for possible effects of turbulent pressure on the scale height: The density decays less rapidly with height than in an (isothermal) hydrostatic stratification.
  - $C = 1.0$ : Density scale height is pressure scale height.
  - $C \geq 1.0$ : Density scale height is smaller than pressure scale height. Not really useful.
- **real c\_radhtautop:**  
The MSrad radiation transport module needs the specification of the scale height of the optical depth at the upper boundary, e.g. with

```
real c_radhtautop f=E15.8 b=4 n='Scale height of optical depth at top' u=cm
  60.0E+05
```

- **real rho\_min:**  
During long periods of matter infall the density at an open outer boundary can become very low. To limit the decrease of the density a lower limit in the extrapolated ghost cells can be set e.g. with

```
real rho_min f=E15.8 b=4 n='Minimum boundary density' u=g/cm^3
1.0E-25
```

The density within the model will typically not fall much below this value. A value of 0.0 (default) or below deactivates this feature.

### 5.3.5 Equation of State

- **character eosfile:**  
The equation of state file together with the opacity file implicitly determine the chemical composition. The EOS file can be specified for instance with

```
character eosfile f=A80 b=80 n='EOS file name' &
c0=eos_gamma140.eos/eos_mm20_1.eos
eos_mm00_13.eos
```

So far, there exists only a relatively small number of files:

- **eos\_mm00\_13.eos:** Standard EOS file for solar composition with extra large density range (towards low densities). There exist two other files for the same composition but smaller density range (**eos\_mm00.eos**, **eos\_mm00\_1.eos**)
- **eos\_mm20\_1.eos:** Standard EOS file for metal-poor star ( $[M/H]=-2.0$ ) with extended range in internal energy and density (towards lower values). The older file (**eos\_mm20.eos**) did not reach far enough.
- **eos\_gamma140.eos:** EOS table for simple gas with constant  $\Gamma=1.4$ . In this case all quantities could be faster computed than by interpolation in a table. Nevertheless, for compatibility reasons (to be able to use the existing EOS Fortran routines), the table is provided.
- **eos\_gamma166.eos:** EOS table for simple gas with constant  $\Gamma=5/3$ .
- **character eospath:**  
The equation of state file does not have to be in the working directory. Instead, its path can be specified e.g. with

```
character eospath f=A80 b=80 n='path of EOS file' &
c0=/astro/b/bf/for/eos/dat
/home/a_bf/for/eos/dat
```

### 5.3.6 Opacities

- **character opafile:**  
The opacity file can be specified with e.g.

```
character opafile f=A80 b=80 n='opacity file name' &
c0=g2va.opta/big_grey.opta &
c1='empty -> no radiation transport'
phoenix_opal_grey.opta
```

So far, there exist already a couple of files:

- **davmf.opta:**
- **f5v.opta:**



- g2va.opta:
- g2v\_lowhe.opta:
- g2v\_m20.opta:
- g2v.opta:
- hmin\_p00.opta:
- opal\_lowhe.opta:
- opal\_m05.opta:
- opal\_m10.opta:
- opal\_m20.opta:
- phoenix\_dust\_grey.opta:
- phoenix\_dust\_ob4.opta:
- phoenix\_opal\_grey.opta:
- ross\_m05.opta:
- ross\_m10.opta:
- ross\_m20.opta:
- sunur1.opta:
- sunur2.opta:
- t5000g44mm20.opta:
- t5000g47mm20.opta:
- t6300g40mm20.opta:
- t6500g44mm20.opta:
- zzceti1g.opta:
- zzceti1.opta:
- **character opapath:**  
The opacity file does not have to be in the working directory. Instead, its path can be specified e.g. with

```
character opapath f=A80 b=80 n='path of opacity file' &
  c0=/astro/b/bf/for/opa/dat
  /home/a_bf/for/opa/dat
```

### 5.3.7 Hydrodynamics Control

- **character hdscheme:**  
With this parameter the type of the hydrodynamics scheme can be specified as in

```
character hdscheme f=A80 b=80 n='Hydrodynamics scheme' &
  c0='Roe (approximate Riemann solver of Roe type)' &
  c1='RoeMagKin (Roe solver + kinetic magnetic field transport)' &
  c2='None (skip hydrodynamics step entirely)'
Roe
```

Possible values are

- **None:** The hydrodynamics step is skipped entirely (for test purposes). Note that in this case some initializations necessary for the generation of the mean file are omitted, too.
- **Roe:** (default) The standard Riemann solver of Roe type is activated. This value will in almost every case be chosen.

- **RoeMagKin:** The standard Roe solver is extended to transport passively a magnetic field. This is a test implementation to check if the general magnetic field handling works.
- **character reconstruction:**  
This parameter determines the order and “aggressiveness” of the reconstruction scheme with e.g.

```
character reconstruction f=A80 b=80 n='Reconstruction method' &
  c0=Constant c1=Minmod/VanLeer/Superbee c2=PP
Minmod
```

Possible values are

- **Constant:** The run of the partial waves inside the cells is assumed to be constant. A highly dissipative first order scheme results. This values will usually only be used for test (or comparison) purposes.
- **Minmod:** Chooses the smallest slope which still results in a second order scheme. It is the most diffusive (and most stable) one in this class.
- **VanLeer:** (default) The recommended second order scheme.
- **Superbee:** The “most aggressive” stable 2nd order scheme. It results in the steepest shocks, which works well in some test cases but might be too difficult for the radiation transport module to handle.
- **PP:** Chooses the piecewise parabolic reconstruction of the PPM scheme (“Piecewise Parabolic Method”, Colella & Woodward 1984). Results in 3rd order accuracy for the advection.

Usually, the **VanLeer** reconstruction is a good choice. If a more stable (and diffusive) scheme is needed, take **Minmod**. The **PP** reconstruction gives the highest accuracy.

- **real c\_slopered:**  
When `-Drhd_roe1d_slope_101=2` is set (see Sect. 3.7), a new extra stabilization mechanism can be activated: If one of the reconstruction methods **VanLeer**, **Superbee**, or **PP** (see Sect. 5.3.7) is activated, the slope can be reduced (by averaging with the results from a **MinMod** reconstruction) by setting `c_slopered` to a positive non-zero value. This value can be set e.g. with

```
real c_slopered f=E15.8 b=4 &
  n='Slope reduction parameter in case of strong density contrast' u=1 &
  c0='0.00: off (default), 0.02: reasonable value, 0.10: large value'
0.02
```

Typical choices are

- 0.0: Slope reduction switched off. Original reconstruction is used.
- 0.02: Moderate slope reduction in case of large density jumps.
- 0.10: More pronounced slope reduction in case of strong density contrast.

- **integer n\_hydcellsperchunk:**  
In every directional sub-step neighboring 1D columns are independent from each other. They can be grouped and computed in chunks of arbitrary size. The approximate number of grid cells per chunk can be specified e.g. with

```
integer n_hydcellsperchunk f=I9 b=4 &
  n='Number of cells per hydro chunk' &
  c0='0 => one 2D slice at a time' &
  c0='1 => minimum chunk size (inefficient)' &
  c0='2500: reasonable value' &
  c0='1000000000: maximum chunk size (inefficient and memory intensive)'
20000
```

The exact number is determined at run time to get (approximately) equal sizes of the individual chunks. The choice of this parameter does not affect the result of the computation but the memory usage and performance: Smaller (and more) chunks may result in an optimum cache usage and need the smallest amount of memory, but result in additional overhead due to frequent subroutine calls. Bigger (and less) chunks are to be preferred for vector machines and processors with large caches. Very rough guide values may be

- 2500: Pentium III processor
- 20000: RISC processor
- 100000: Vector machine

Note: For simulations with activated OpenMP on a parallel machine the chunk size has to be made small enough to allow at least as many chunks as processors available. This is particularly important for models with a small number of grid points (e.g. 2D models). An example is given for the Hitachi SR8000 in Sect. 3.8.5.

- **real c\_visdrag:**

This viscosity parameter controls the drag force which is (if requested) applied inside the hydrodynamics routines themselves. It does not act on velocity gradients as usual viscosity but applies a force proportional to the velocity itself (but with the opposite sign). The amount can be specified e.g. with

```
real c_visdrag f=E15.8 b=4 &
      n='Drag viscosity parameter' u=1
0.001
```

The value gives the fraction the velocity is reduced per time step. Therefore, reasonable values lie between 0.0 and 1.0. In almost every case the drag forces will be switched off ( $c\_visdrag=0.0$ ). If e.g. strong pulsation have to be damped in the initial phase of a simulation a value around 0.001–0.01 seems appropriate.

- **real c\_visbound:**

An additional drag force can be added locally in inflow cells in the outer layer when the transmitting boundary condition is chosen. The value can be set e.g. with

```
real c_visbound f=E15.8 b=4 &
      n='Boundary drag viscosity parameter' u=1
0.001
```

This extra drag force is usually not necessary and should be switched off (with  $c\_visbound=0.0$ ).

### 5.3.8 Tensor Viscosity Control

In many test problems it is not necessary to activate the 2D/3D tensor viscosity. But when strong slow shock fronts are aligned with the grid the Roe solver runs into problems and at least some additional 2D or 3D viscosity is necessary. And even if the Roe solver can handle sharp shocks by its own, the radiation transport algorithm might cause trouble because of the enormous opacity variations across a shock front. Here the tensor viscosity is useful, too.

- **real c\_vissmagorinsky:**

A turbulent viscosity of Smagorinsky type can be activated e.g. with

```
real c_vissmagorinsky f=E15.8 b=4 &
      n='Turbulent eddy viscosity parameter (Smagorinsky type)' u=1
1.2
```

In many cases values around 0.5 are sufficient to stabilize the code. Larger values (1.2 in the example above) are only necessary for some nasty under-resolved supergiant models. Setting  $c\_vissmagorinsky = c\_visartificial = 0.0$  skips the tensor viscosity step entirely.

- **real c\_visartificial:**

A standard artificial viscosity can be activated e.g. with

```
real c_visartificial f=E15.8 b=4 &
      n='Artificial viscosity tensor parameter'           u=1
1.2
```

In many cases values around 0.5 are sufficient to stabilize the code. Larger values (1.2 in the example above) are only necessary for some nasty under-resolved supergiant models. Setting `c_vissmagorinsky = c_visartificial = 0.0` skips the tensor viscosity step entirely.

- **real c\_visprturb:**

The Prandtl number for turbulent mixing can be specified e.g. with

```
real c_visprturb f=E15.8 b=4 &
      n='Turbulent Prandtl number'                       u=1
8.0
```

Values between 1.0 and 10.0 appear reasonable. Note that larger values lead to smaller amounts of turbulent mixing! A value of 0.0 switches off the turbulent mixing terms (but not the entire tensor viscosity).

- **real c\_vistensordiag:**

The factor in the stress tensor in front of of the diagonal terms can be set with

```
real c_vistensordiag f=E15.8 b=4 &
      n='Diagonal factor for viscous stress tensor'       u=1 &
      c0='typically 1.0'
1.0
```

This is not really parameter one would try to adjust. The total amount of viscosity should be controlled with `real c_vissmagorinsky` and `real c_visartificial`. But the parameter can be used to tentatively switch off the diagonal terms completely or to change its importance compared to the other terms.

- **real c\_vistensoroff:**

The factor in the stress tensor in front of of the off-diagonal terms can be set with e.g.

```
real c_vistensoroff f=E15.8 b=4 &
      n='Off-diagonal factor for viscous stress tensor'   u=1 &
      c0='typically 0.5'
0.5
```

This is not really parameter one would try to adjust. The total amount of viscosity should be controlled with `real c_vissmagorinsky` and `real c_visartificial`. But the parameter can be used to tentatively switch off the off-diagonal terms completely or to change its importance compared to the other terms.

- **real c\_vistensordiv:**

The factor in the stress tensor in front of of the divergence terms (also on the diagonal) can be set with e.g.

```
real c_vistensordiv f=E15.8 b=4 &
      n='Divergence factor for viscous stress tensor'     u=1 &
      c0='typically -1./3.'
0.0
```

This is not really parameter one would try to adjust. The total amount of viscosity should be controlled with `real c_vissmagorinsky` and `real c_visartificial`. But the parameter can be used to switch off the divergence terms completely or to change its importance compared to the other terms. These divergence terms can be used to reduce the effect of the tensor viscosity in the case of isotropic compression. But this reduction (`c_vistensordiv = -0.333333` in 3D, `c_vistensordiv = -0.5` in 2D) is usually switched off.

- **integer n\_viscellsperchunk:**

The number of cells per box (or “chunk”) treated by the tensor viscosity scheme at one call (and by one thread) can be set e.g. with

```
integer n_viscellsperchunk f=I9 b=4 &
  n='Number of cells per viscosity chunk' &
  c0='0 => old chopping' &
  c0='12000: reasonable value'
20000
```

It can be adjusted to improve cache efficiency and to modify the work load distribution onto the threads (in case of parallel runs with OpenMP). Due to the special handling of boundary cells the overhead per call increases significantly for small chunks. Typically larger chunk sizes (compared to the hydrodynamics chunk sizes set with `integer n_hydcellsperchunk`, see Sect. 5.3.7) are adequate. On the other hand they should not be too large to limit the usage of temporary memory and to allow parallelization (the distribution of chunks to threads): For simulations with activated OpenMP on a parallel machine the chunk size has to be made small enough to allow at least as many chunks as processors available. This is particularly important for models with a small number of grid points (e.g. 2D models). An example is given for the Hitachi SR8000 in Sect. 3.8.5.

### 5.3.9 Dust/Molecules

CO5BOLD can now handle a number of additional density arrays. They can be used to describe e.g. the mass density of dust distribution moments or number densities of molecules. These species are properly advected with the gas density. There is also already a small number of dust/molecule formation models available. These models have to be improved in the future and the influence on the radiation field (opacities, radiation pressure on dust) has to be taken into account.

- **character dustscheme:**

A scheme for dust or molecule formation and transport can be selected e.g. with

```
character dustscheme f=A80 b=80 n='Dust model' &
  c0='none (default), nosource, dust_simple_01, co_component01_01' &
  c1='dust_k3mon_01, dust_k3mon_02'
dust_k3mon_01
```

Possible values are (the list is hopefully expanded in the near future):

- **none, None:** No handling of any dust/molecule density at all.
  - **nosource:** Skip source term step for dust/molecules entirely, but do the transport.
  - **dust\_simple\_01:** Simple and unrealistic 'dust' formation model (only for testing of the numerics).
  - **co\_component01\_01:** Simple CO formation (from Matthias Steffen) with one component only but realistic time scales.
  - **dust\_k3mon\_01:** Simple C-rich dust formation (from Susanne Höfner) with one component only but realistic time scales.
  - **dust\_k3mon\_02:** Simple C-rich dust formation (from Susanne Höfner) with two components for dust density and free carbon density.
- **real c\_dust0X:**
- There are five parameters (`real c_dust01` to `real c_dust05`) to control each dust formation scheme in detail. A parameter can be given as in

```
real c_dust01 f=E15.8 b=4 n='Dust parameter 1'
0.0
```

The meaning (and unit) can vary from scheme to scheme. The default value is 0.0 in each case.

### 5.3.10 Radiation Transport Control

In this part of the parameter file the radiation transport module has to be selected. Depending on this selection a couple of additional parameters have to be specified. Table 12 gives a list of the parameters and the modules they apply to. The standard routines are now in the MSrad module for local models and the SHORTrad module for global “Star-in-a-Box” models. The LHDrad module is not maintained very much anymore.

Parameter	Section	LHDrad	MSrad	SHORTrad
radscheme	5.3.10	*	*	*
n_radminiter	5.3.10	*	*	*
n_raditer	5.3.10	*	*	*
n_radmaxiter	5.3.10	*	*	*
radraybase	5.3.10	*		*
radraystar	5.3.10	*		*
n_radtheta	5.3.10		*	
n_radphi	5.3.10		*	
n_radsubray	5.3.10		*	
n_radthinpoint		*		
n_radthickpoint	5.3.10	*	*	
n_radtaurefine	5.3.10	*	*	
n_radband	5.3.10		*	
c_radimplicitmu	5.3.10	*		*
c_raditereps	5.3.10	*		*
c_raditerstep	5.3.10	*		*
c_radtvisdtau	5.3.10	*		
c_radtvis	5.3.10	*		
c_radhtautop	5.3.4		*	
c_radcourant	5.3.12	*	*	*
c_radcourantmax	5.3.12	*	*	*
c_radmaxeichange	5.3.12	*	*	*

Table 12: List of radiation transport control parameters and the modules they are relevant for.

- **character radscheme:**

So far, there exist three different radiation transport modules. The active one can be selected e.g. with

```
character radscheme f=A80 b=80 n='Radiation transport scheme' &
  c0='LHDrad/MSrad/SHORTrad' &
  c1='None (skip radiation transport step entirely)'
SHORTrad
```

Possible values are

- **None:** Skip radiation transport entirely.
- **LHDrad:** (old “supergiant module”) It uses long characteristics and is restricted to an equidistant grid and open boundaries at all surfaces. Note that the switch `-Drhd_r01=1` has to be set during compilation (see Sect. 3.7).
- **MSrad:** (“solar module”) It uses long characteristics. The lateral boundaries have to be periodic. Top and bottom can be closed or open. Note that the switch `-Drhd_r02=1` has to be set during compilation (see Sect. 3.7).
- **SHORTrad:** (new “supergiant module”) It uses short characteristics and is restricted to an equidistant grid and open boundaries at all surfaces. Note that the switch `-Drhd_r03=1` has to be set during compilation (see Sect. 3.7).

- **integer n\_radminiter:**

Usually the stability considerations dictate a radiative time step smaller than the hydrodynamics or tensor viscosity time step. To remedy this situation it is possible to allow several radiation transport steps per global time step. Hitherto, all three radiation transport modules support this iteration. The minimum number of iterations (radiative sub-steps) can be specified e.g. with

```
integer n_radminiter f=I4 b=4 &
  n='Minimum number of radiation transport iterations' c0=8
1
```

If less iterations are needed the time step limit for the next step is increased. This value will in almost any case (for explicit radiation transport) be set to 1. In the implicit case it is set to a higher value (typically 5).

- **integer n\_raditer:**

After each complete radiative time step the recommendation for the next time step will be chosen so that `n_raditer` iterations will (probably) be needed. The parameter can be set e.g. with

```
integer n_raditer f=I4 b=4 &
  n='Number of radiation transport iterations' c0=10
8
```

For a simulation of a solar-type star (with comparatively long radiative time scales) it will typically be set to 1. For stars with shorter radiative time scales values around 10 may be considered. All three radiation transport modules understand this parameter.

- **integer n\_radmaxiter:**

The absolute maximum number of iterations can be specified e.g. with

```
integer n_radmaxiter f=I4 b=4 &
  n='Maximum number of rad. transport iterations' c0=30
0
```

If more iterations are needed the computation for the current time step is stopped and resumed with a smaller one (which means that the hydrodynamics and the tensor viscosity step have to be done again). Usually, `n_radmaxiter` will either be set to a value somewhat larger than the recommended number of iterations (`n_raditer`) or to 0 which disables the check for too many iterations completely. This can be safely allowed in many cases and has the advantage that there is no need to save the initial model before calling the radiation transport module, which saves some memory. To disable the iteration of the radiation transport sub-step set `n_radminiter=n_raditer=n_radmaxiter=1`. All three radiation transport modules understand this parameter.

- **character radraybase:**

Using the modules `LHDrad` or `SHORTrad` the orientation of the base axis system can be selected e.g. with

```
character radraybase f=A80 b=80 n='Base axis system' &
  c0='unity/random/randomgroup'
random
```

Allowed values are

- **unity:** (default) During all time steps and radiative sub-steps the direction of the rays stays the same.
- **random:** At each time step (and radiative sub-step) a new base axis system is chosen at random

- `randomgroup`: At each new time step a new base axis system is chosen at random. It is kept for all radiative sub-steps.

Because typically only a relatively small number of rays is chosen per time step (with `radraystar`) it is advisable to vary the directions of the rays (by choosing `radraybase=random` or `randomgroup`) to cover the entire sphere at least over a longer time.

- **character `radraystar`:**

Using the modules `LHDrad` or `SHORTrad` the list of ray directions (i.e. the number of rays and their coordinates) relative to the base axis system can be specified with e.g.

```
character radraystar f=A80 b=80 n='List of relative ray directions' &
  c0='x1(1)/x2(1)/x3(1)/oktaeder(3)/tetraeder(4)/cube(4)' &
  c1='ikosaeder(6)/dodekaeder(10)'
oktaeder
```

Examples for allowed values are

- `x1`: (N=1) one single ray along x1 axis (not enough to specify fluxes in all directions)
- `x2`: (N=1) one single ray along x2 axis (not enough to specify fluxes in all directions)
- `x3`: (N=1) one single ray along x3 axis (not enough to specify fluxes in all directions)
- `oktaeder`: (N=3, default) octahedron
- `tetraeder`: (N=4) tetrahedron
- `cube`: (N=4)
- `ikosaeder`: (N=6) icosahedron
- `dodekaeder`: (N=10) dodecahedron
- `list-01`, `list-01(3)`: Choose ray systems from a list (oktahedrons, tetrahedrons). If `character radraybase` is set to `unity` the rays will only be aligned to the axes or diagonals and thus avoid the time-consuming interpolation step of the short-characteristics method.

Several other choices are possible, which are meant for test purposes only. Choosing one of the five Platonic solids (Ops! “German-Greek” names only, so far) means that the 3 to 10 rays are equally distributed over the solid angle (from the center to each *corner* of the respective solid).

- **integer `n_radtheta`:**

Using the `MSrad` module the ray directions have to be specified in a different way: The number of ray sets in theta direction can be chosen with e.g.

```
integer n_radtheta f=I4 b=4 &
  n='NTHETA: Number of ray sets in theta direction' c0=2
2
```

- **integer `n_radphi`:**

Using the `MSrad` module the number of ray sets in phi direction can be set e.g. with

```
integer n_radphi f=I4 b=4 &
  n='NPHI: Number of ray sets in phi direction' c0=2
2
```

- **integer `n_radsubray`:**

Using the `MSrad` module the number of rays per cell (with the same direction) can be specified e.g. with



```
integer n_radsubray f=I4 b=4 n='KPHI: Number of rays per cell' c0=2
2
```

- **integer n\_radthickpoint:**

With the MSrad module the lower part of the model can be computed in diffusion approximation. The number of points in diffusion approximation can be set with e.g.

```
integer n_radthickpoint f=I4 b=4 &
  n='Number of grid points with optically thick (diff.) approximation' &
  c0='0: no diffusion approximation'
0
```

Setting this value to 0 means that the diffusion approximation is not used in any part of the model.

- **integer n\_radtaurefine:**

With the LHDrad and the MSrad module the number of points on the rays can be finer than the number of points in the basic numerical grid. The refinement can be set e.g. with

```
integer n_radtaurefine f=I4 b=4 &
  n='Refinement factor'
0
```

- **integer n\_radband:**

It can be specified whether the grey opacity table or the binned frequency-dependent part of the opacity table is used during the computation. The grey part contains only one bin. The other (possibly non-grey) contains one or more bins depending on the table chosen. The parameter is specified with e.g.

```
integer n_radband f=I4 b=4 n='Number of frequency bins' &
  c0='1: grey opacities' &
  c1='2: non-grey opacities (if available from table)'
1
```

Allowed values are

- 1: Use the grey part of the table
- 2: Use the other (possibly non-grey, frequency-dependent) part of the table

Only the MSrad module so far can handle non-grey tables.

- **real c\_radimplicitmu:**

So far only the LHDrad and the SHORTrad module (tentatively) support implicit radiation transport. It can be activated with the parameter

```
real c_radimplicitmu f=E15.8 b=4 &
  n='Implicitness parameter for radiation transport' u=1 &
  c0='0.0: explicit / 0.5: time centered / 1.0: fully implicit'
0.0
```

Allowed values are

- 0.0: Fully explicit radiation transport (possible with all modules)
- $0.0 < C < 1.0$ : Partly implicit radiation transport
- 0.5: Radiation transport time-centered
- 1.0: Fully implicit radiation transport

Values outside this range do not have much meaning. The implicit transport does not work efficiently yet: It does not yield significantly larger time steps than possible with a sequence of purely explicit sub time steps. Additionally, it turns out that the hydrodynamics runs into trouble if a too large time step (still well within the Courant condition) is requested.

- **real c\_raditereps:**  
With activated implicit radiation transport (LHDrad module only) the requested convergence accuracy of the iteration can be set e.g. with

```
real c_raditereps f=E15.8 b=4 &
  n='Relative accuracy for radiation iteration'          u=1 &
  c0='Typical value: 1.0E-03'
2.0E-03
```

- **real c\_raditerstep:**  
With activated implicit radiation transport (LHDrad module only) the step size of the iteration can be restricted with e.g.

```
real c_raditerstep f=E15.8 b=4 &
  n='Step size of radiation iteration'                  u=1 &
  c0='Typical values: 0.7,0.81'
1.0
```

Allowed values are

- 0.0 < 1.0: Restricted step size
- 1.0: No restriction, standard step size
- > 1.0: Extra large steps

This value has to be chosen carefully to get optimal performance. Is the step size too small the convergence is safe but too slow. A too large step size inhibits convergence and leads to a decrease in the time step, which results in a bad performance, too.

- **real c\_radtvisdtau:**  
Using the LHDrad module the limit in delta optical depth ( $\rho \cdot \kappa \cdot dx$ ) below which the “radiative temperature viscosity” (=temperature smoothing) is to be applied can be set with e.g.

```
real c_radtvisdtau f=E15.8 b=4 &
  n='Optical depth limit for temperature viscosity' u=1
0.1
```

The introduction of this “temperature diffusion” is a somewhat desperate and inelegant attempt to improve the behavior of the Greens function (hot cells should be cooled, cool cells should be heated). This diffusion is necessary for not well resolved models. It is switched off with  $c\_radtvisdtau \leq 0.0$ .

- **real c\_radtvis:**  
Using the LHDrad module the amount of the “radiative temperature viscosity” (=temperature smoothing) can be specified e.g. with

```
real c_radtvis f=E15.8 b=4 n='Temperature viscosity' u=1
1.6
```

For well resolved models it should be switched off (with  $c\_radtvis \leq 0.0$ ). But often its use is necessary.

### 5.3.11 Process Time Management

In this group several parameters can be set which control the start of the time counting during a simulation and the total length of a job. If either one of the halt conditions below is met, CO5BOLD finishes the current step, writes a final model (plus some final information to other files), and stops execution.

For example on a CRAY one typically wants to use most of the CPU time given for an individual batch job. In this case one can set e.g. `real cputime_remainlimit=2000.0` and the values for the other halt conditions to `-1.0` or `-1`.

- **real starttime:**

The start time of a simulation is usually taken from the start model file. But sometimes is simulation is to be started with the final model of a previous run but should start at `time=0.0`. This can be achieved by setting the start time with

```
real starttime f=E15.8 b=4 n='Start time'          u=s
0.0
```

Allowed values are

- $\geq 0.0$ : Set the initial time of the simulation to this value and override value from start model.
- $< 0.0$ : (default) Take the initial time from start model.

- **integer starttimestep:**

The start time step count of a simulation is usually taken from the start model file. But sometimes is simulation is to be started with the final model of a previous run but should start at `time step=0`. This can be achieved by setting the start time step count with

```
integer starttimestep f=I11 b=4 n='Start time step number'      u=1
0
```

Allowed values are

- $\geq 0$ : Set the initial time step of the simulation to this value and override value from start model.
- $< 0$ : (default) Take the initial time step count from start model.

- **real cputime:**

Because of the long simulation time usually CO5BOLD will run in some sort of batch mode which might impose limits on the execution time per run. On a CRAY the CPU time that is left can be accessed with a special subroutine (in `call tremain` in `rhd_mac_cray_module.f90`). On other machines it is possible to specify the allowed total time for the job e.g. with

```
real cputime f=E15.8 b=4 n='CPU time'          u=s
1000000.0
```

During the run of CO5BOLD the leftover CPU time is computed by subtracting the used CPU time (which is given by `e_time=etime(tarray)` in `rhd_mac_sun_module.f90`) from the specified total CPU time for the job.

- **real cputime\_remainlimit:**

Because CO5BOLD needs some time to finish the last time step it should start exiting well before all CPU time is used up. This amount of buffer CPU time can be specified e.g. with

```
real cputime_remainlimit f=E15.8 b=4 n='maximum remaining CPU time'  u=s
2000.0
```

Its value depends on the size of the model and the speed of the machine (more precisely the maximum CPU time per time step).

- **real endtime:**

If the simulation should run up to a certain (stellar) time, its values can be specified e.g. with

```
real endtime f=E15.8 b=4 n='total simulation time limit'      u=s
10000.0
```

A value  $< 0.0$  deactivates this halt condition: it is not checked at all. If this parameter is set to a non-negative value a follow-up simulation should not use the same parameter file: it would stop immediately.

- **real plustime:**

If the initial model should be advanced by a certain (stellar) time span, this value can be set e.g. with

```
real plustime f=E15.8 b=4 n='simulation advance time'        u=s
5.0E+07
```

A value  $< 0.0$  cancels this halt condition: it is not checked at all. This condition assures (if it is the only one) that all individual simulation runs cover (approximately) the same stellar time.

- **integer endtimestep:**

If the simulation should run up to a certain time step, its values can be specified e.g. with

```
integer endtimestep f=I11 b=4 n='total simulation time step number'  u=1
1234
```

This might be useful to advance the simulation up to a point shortly before a previous simulation crashed. A value  $< 0$  cancels this halt condition: it is not checked at all.

- **integer plustimestep:**

If the initial model should be advanced by a certain number of time steps their number can be set e.g. with

```
integer plustimestep f=I11 b=4 n='simulation advance time step number' u=1
2000
```

A value  $< 0$  deactivates this halt condition: it is not checked at all.

### 5.3.12 Time Step Control

In this group parameters to control the time step restrictions can be set.

They are important because decide about performance and stability of CO5BOLD. They should be tested and adjusted for a simulation of a new type of object. But all the dimensionless parameters can stay unchanged for a group of similar simulations. Only the parameters with an explicit time dimension should be checked in all cases (they scale with characteristic timescales and depend particularly on gravity).

- **real dtime\_start:**

The initial time step recommendation of a simulation is usually taken from the start model file. It can be overwritten e.g. with

```
real dtime_start f=E15.8 b=4 n='Start time step'            u=s
1.0E+03
```

A value  $< 0.0$  means that the original value from the start model is used.

- **real dtime\_min:**

In some rare cases it might be useful to specify explicitly the minimum time step with e.g.

```
real dtime_min f=E15.8 b=4 n='Minimum time step'          u=s &
  c0='dtime_min=0.0 => no restriction'
1.0
```

This value is used even if restrictions from the Courant condition try to enforce a smaller value. A fixed time step can be prescribed by setting `dtime_min = dtime_max` to some positive value. A value `dtime_min ≤ 0.0` means that this time step restriction is completely ignored, which is the case that should usually be chosen.

- **real dtime\_max:**

It is possible to explicitly specify the maximum time step too, e.g. with

```
real dtime_max f=E15.8 b=4 n='Maximum time step'          u=s &
  c0='dtime_max=0.0 => no restriction'
1.0E+05
```

A fixed time step can be prescribed by setting `dtime_min = dtime_max` to some positive value. A value `dtime_max ≤ 0.0` means that this time step restriction is completely ignored, which is the case that should usually be chosen.

- **real dtime\_min\_stop:**

Sometimes a simulation can run into a pathological state where the time step decreases rapidly without recovering. To prevent a simulation in such a case from running forever (or until some other process time restriction applies) without actually advancing significantly in time, it is possible to specify an absolute minimum time step, e.g. with

```
real dtime_min_stop f=E15.8 b=4 n='Minimum time step'      u=s &
  c0='dtime_min_stop=0.0 => no restriction' &
  c1='dtime < dtime_min_stop => program stop'
1.0
```

If the actual time step falls below this value, the simulation finishes gracefully. This value has to be specified as absolute time and has to be chosen carefully for each individual model (or each group of models). This time step restriction can be switched off by setting `real dtime_min_stop=0.0`. But in general, one should keep it activated and try to find a proper positive value.

- **real dtime\_incmax:**

Sometimes a time step restriction can lead to a sudden drastic drop in the time step. To prevent unwanted oscillations in the size of the time step its increase can be restricted e.g. with

```
real dtime_incmax f=E15.8 b=4 n='Maximum time step increment factor' u=1 &
  c0='dtime_max<1.0 => no restriction' c1='typically 1.1'
1.2
```

This value specifies the maximum factor by which the time step can be increased from step to step (even if the new Courant condition etc. would allow more). A value `value < 0.0` deactivates this restriction.

- **real c\_courant:**

A typical Courant factor for each 1D hydrodynamics step can be specified with e.g.

```
real c_courant f=E15.8 b=4 n='HD Courant factor'          u=1 &
  c0='range: 0.0 < C_Courant <= 1.0, typically: 0.5'
0.5
```

From the minimum cell crossing time of a partial wave and this factor a recommendation for the *next* time step is computed. A value of 1.0 is the upper limit which guarantees stability for some simple linear test problems. Values around 0.5 are recommended for fully non-linear simulations.

- **real c\_courantmax:**

A typical Courant factor for each 1D hydrodynamics step can be specified with e.g.

```
real c_courantmax f=E15.8 b=4 n='maximum HD Courant factor'          u=1 &
  c0='range: C_Courant < C_Courantmax <= 1.0, typically: 0.9'
  0.8
```

From the minimum cell crossing time of a partial wave and this factor an upper limit for the *current* time step is computed. If this limit is exceeded the computation is interrupted and resumed with a smaller time step (based on `c_courant`). Usually this parameter should be restricted by `c_courant < c_courantmax ≤ 1.0`. A value around 0.8 appears to be a good choice.

- **real c\_maxeichange:**

The relative change in internal during a single 1D hydrodynamics step can be used to restrict the time step by specifying

```
real c_maxeichange f=E15.8 b=4 n='maximum hydro energy change'      u=1 &
  c0='range: 0.1 - 1.0, typically 0.5, off:0.0'
  0.5
```

The default is 0.9. Nevertheless, since the Roe solver is constructed to handle shocks and rapid changes in density and energy, this check is usually not needed. It can be switched off by setting `c_maxeichange=0.0`.

- **real c\_radcourant:**

The radiation transport routines are subject so time step restrictions, too. And in typical scenarios, its the radiative timescale are the shortest one and poses the tightest restriction. Contrary to the hydrodynamics routines the timescale relevant for the stability of the radiation transport scheme can only be estimated using the characteristic timescale of a small sinusoidal temperature disturbance with a wavelength of the grid size in a homogeneous background and grey radiative energy exchange. The “radiative Courant” factor can be set e.g. with

```
real c_radcourant f=E15.8 b=4 n='RAD Courant factor'                  u=1 &
  c0='range: 0.0 < C_radCourant, typically: 1.0'
  2.5
```

If the estimate of the timescale would be correct a value of 2.0 would cause the temperature fluctuation on the shortest scale to flip its sign, setting the absolute stability limit. A value of 1.0 would lead to a damping of theses fluctuations within one time step. But in practice, even higher values (for example 2.5) show a reasonable behavior. This might be due to the effect that the shortest radiative timescale only occurs at single points (or in 2D layers) but that already the immediate neighbors have longer timescales and can damp the “most sensitive points”. Based on `real c_radcourant` the recommended typical radiative time step is computed.

- **real c\_radcourantmax:**

With this parameter the maximum allowed radiative time step is prescribed as e.g. in

```
real c_radcourantmax f=E15.8 b=4 n='maximum RAD Courant factor'      u=1 &
  c0='range: C_radCourant <= C_radCourantmax, typically: 2.0'
  3.0
```

This value will typically be somewhat larger than `real c_radcourant`.

- **real c\_radmaxeichange:**

The relative energy change per radiative sub step can be restricted e.g. with

```
real c_radmaxeichange f=E15.8 b=4 n='maximum radiative energy change' &
  u=1 c0='range: 0.01 - 1.0'
0.25
```

The default is 0.5. Values between 0.1 and 0.5 seem reasonable. A value  $\leq 0.0$  deactivates this time step check. However, the check of the radiative energy change should usually be performed. A way to maximize the radiative time step (and therefore the performance of the entire code) can be to first set **real c\_radmaxeichange** to a proper value (say 0.25). Then, **real c\_radcourant** (and **real c\_radcourantmax**) are adjusted (by trial and error) in a way that the radiative time step is almost always restricted by the “Courant” condition and only sometimes in extreme cases by the maximum energy change restriction. The computed output intensity should be checked for the size of its fluctuations due to a possibly too large value of **c\_radmaxeichange**.

- **real c\_radthintimefac:**

In the LHDrad module only the radiative time step restriction due to energy changes can be relaxed further in the optically thin by specifying e.g.

```
real c_radthintimefac f=E15.8 b=4 &
  n='time scale reduction in optically thin' u=1 &
  c0='range: 0.1 - 1.0, typically: 0.5'
0.60
```

A value  $\leq 0.0$  or **real c\_radtvisdtau**  $\leq 0.0$  switches off this relaxation.

- **real c\_viscourant:**

The tensor viscosity routines have their own time step restriction. The recommended typical viscous time step can be set e.g. with

```
real c_viscourant f=E15.8 b=4 n='viscous Courant factor' u=1 &
  c0='range: 0.0 < C_visCourant, typically: 0.5-1.0, better 0.25'
0.5
```

As the corresponding viscous timescale is typically longer than the radiative one (and even the Courant timescale from the Roe hydrodynamics routines) this factor is often irrelevant. The absolute upper stability limit is located at **c\_viscourant**=2.0. Values around 0.5 to 1.0 are more typical. In some extreme cases in simulations of the solar chromosphere it has turned out that an even lower value (0.2) is necessary to prevent some spikes in the neighborhood of strong colliding shocks.

- **real c\_viscourantmax:**

The absolute upper limit for the viscous time scale can be set with

```
real c_viscourantmax f=E15.8 b=4 n='maximum viscous Courant factor' u=1 &
  c0='range: C_visCourant <= C_visCourantmax, typically smaller than 2.0'
1.0
```

Its value should be slightly above **c\_viscourant** and below 2.0.

### 5.3.13 Input/Output Control

With this group of parameters the start model and the type and amount of output can be specified. Parameters with the suffix “\_start” describe the initial model, these with suffix “\_end” the corresponding final model. Additional data can be written into the file described by the parameters with suffix “\_full” (full 2D/3D model dumps, huge, see Sect. 5.1) or into the file described by the parameters with suffix “\_mean” (additional information, see Sect. 5.2).

- **real dttime\_out\_full:**

The interval between datasets in the full file can be set e.g. with

```
real dttime_out_full f=E15.8 b=4 n='Output time step'          u=s &
  c0='dttime_out_full < 0.0 => no output' &
  c1='dttime_out_full = 0.0 => output every time step'
  2.0E+06
```

Allowed values are

- $< 0.0$ : No output to this file
- $= 0.0$ : Output at every time step. Attention: This can produce HUGE files in no time.
- $> 0.0$ : Output to full file approximately every `dttime_out_full` seconds.

Some examples: The “classical” value for this output for simulations of solar granulation is 20sec. To save memory this can be increased to 30sec. But in this case chromospheric shocks are very badly resolved. To cover them properly, a sampling rate of 10sec or below is needed.

- **real dttime\_out\_mean:**

The interval between datasets in the mean file can be set e.g. with

```
real dttime_out_mean f=E15.8 b=4 n='Output time step'          u=s &
  c0='dttime_out_mean<0.0 => no output'
  0.5E+06
```

Allowed values are

- $< 0.0$ : No output to this file
- $= 0.0$ : Output at every time step.
- $> 0.0$ : Output to mean file approximately every `dttime_out_mean` seconds.

Because the size of one mean dataset is much smaller than one full dataset, it is possible to request a higher sampling rate without using too much disk space.

- **character infile\_start:**

The filename of the initial model is specified e.g. with

```
character infile_start f=A80 b=80 n='File name of start model'
rhd.sta
```

Default is `rhd.sta` (for a parameter file used within a batch system). Typical filenames are `st35gm04n01_01.sta` or `gt57g44n20dz.end`.

- **character outfile\_end:**

The file name for the final model can be specified with e.g.

```
character outfile_end f=A80 b=80 n='Output file name'
rhd.end
```

The default is `rhd.end`. Leaving it empty means that no final model is written. This of course inhibits follow-up simulations but can be useful to save time and disk space for some tests.

- **character outfile\_full:**

The name of the file for the output of additional full models at regular intervals (see Sect. 5.1) can be given with e.g.



```
character outfile_full f=A80 b=80 n='Output file name'
rhd.full
```

Leaving it empty means that no file of this type is written.

- **character outfile\_mean:**  
The name of the file for the output of additional information (average stratification, mean fluxes, surface intensities) at regular intervals (see Sect. 5.2) can be specified with e.g.

```
character outfile_mean f=A80 b=80 n='Output file name'
rhd.mean
```

Leaving it empty means that no file of this type is written.

- **character outform\_end:**  
The format (see Sect. 4.3.1) of the final model files can be chosen e.g. with

```
character outform_end f=A80 b=80 n='Output file format' &
  c0='formatted/unformatted'
unformatted
```

Allowed values are

- **unformatted:** (default) fast compact (possibly machine-dependent) output: strongly recommended
  - **formatted:** slow (machine-independent) output, big files
- **character outconv\_end:**  
The conversion type (see Sect. 4.3.1) of the final model files can be specified e.g. with

```
character outconv_end f=A80 b=80 n='Output file conversion' &
  c0='ieee_4/ieee_8/crayxmp_8/native'
ieee_4
```

The allowed values depend on the machine. Leaving this field empty means that the default is chosen that is build into the local UIO module. If the type `ieee_4` is supported (which is always the case, so far) it should be chosen.

- **character outform\_full:**  
The format (see Sect. 4.3.1) of the **full** model files can be chosen e.g. with

```
character outform_full f=A80 b=80 n='Output file format' &
  c0='formatted/unformatted'
unformatted
```

Allowed values are

- **unformatted:** (default) fast compact (possibly machine-dependent) output: strongly recommended
  - **formatted:** slow (machine-independent) output, big files
- **character outconv\_full:**  
The conversion type (see Sect. 4.3.1) of the **full** model files can be specified e.g. with

```
character outconv_full f=A80 b=80 n='Output file conversion' &
  c0='ieee_4/ieee_8/crayxmp_8/native'
ieee_4
```

The allowed values depend on the machine. Leaving this field empty means that the default is chosen that is build into the local UIO module. If the type `ieee_4` is supported (which is always the case, so far) it should be chosen.

- **character outform\_mean:**  
The format (see Sect. 4.3.1) of the additional data files can be chosen e.g. with

```
character outform_mean f=A80 b=80 n='Output file format' &
  c0='formatted/unformatted'
unformatted
```

Allowed values are

- **unformatted:** (default) fast compact (possibly machine-dependent) output: strongly recommended
  - **formatted:** slow (machine-independent) output, big files
- **character outconv\_mean:**  
The conversion type (see Sect. 4.3.1) of the additional data files can be specified e.g. with

```
character outconv_mean f=A80 b=80 n='Output file conversion' &
  c0='ieee_4/ieee_8/crayxmp_8/native'
ieee_4
```

The allowed values depend on the machine. Leaving this field empty means that the default is chosen that is build into the local UIO module. If the type `ieee_4` is supported (which is always the case, so far) it should be chosen.

### 5.3.14 Additional Information, Obsolete and Test Parameters

- **real abux:**  
This optional information parameter can be specified with

```
real abux f=E15.8 b=4 n='hydrogen abundance (number fraction)' u=1 &
  c0='standard solar mixture'
0.90851003E+00
```

It has no practical consequences because the actually used chemical composition is determined by the files for equation of state and opacity.

- **real abuy:**  
This optional information parameter can be specified with

```
real abuy f=E15.8 b=4 n='helium abundance (number fraction)' u=1 &
  c0='standard solar mixture'
0.90850003E-01
```

It has no practical consequences because the actually used chemical composition is determined by the files for equation of state and opacity.

- **real qmol:**  
This optional information parameter can be specified with

```
real qmol f=E15.8 b=4 n='mean molecular weight' u=u &
  c0='standard solar mixture'
0.13018000E+01
```

It has no practical consequences because the actually used chemical composition is determined by the files for equation of state and opacity.

- **real gamma:**  
This optional information parameter can be specified with

```
real gamma f=E15.8 b=4 n='Adiabatic coefficient'          u=1 &
      c0='0.0/1.666666666666666/1.4'
0.0
```

It has no practical consequences because the actually used chemical composition is determined by the files for equation of state and opacity.

- **real c\_visneu1:**

```
real c_visneu1 f=E15.8 b=4 &
      n='Linear viscosity parameter (von Neumann-Richtmyer type)' u=1
0.0
```

- **real c\_visneu2:**

```
real c_visneu2 f=E15.8 b=4 &
      n='Quadratic viscosity parameter (von Neumann-Richtmyer type)' u=1
0.0
```

- **real c\_radkappasmooth:**

In the LHDrad module the opacity along each ray can be smoothed. The amount of smoothing can be set e.g. with

```
real c_radkappasmooth f=E15.8 b=4 n='Opacity smoothing parameter' u=1 &
      c0='0.0: no smoothing, 0.25: light smoothing, 0.666: strong smoothing'
0.0
```

The smoothing can perhaps reduce the noise in the intensity images somewhat but has no general beneficial effect and should usually not be used.

- **real c\_radtsmooth:**

In the LHDrad module the 3D temperature array can be smoothed. The amount of smoothing can be set e.g. with

```
real c_radtsmooth f=E15.8 b=4 n='Temperature smoothing parameter' u=1 &
      c0='0.0: no smoothing, 0.5: reasonable smoothing, 1.0: max. smoothing'
0.0
```

The smoothing can sometimes reduce the noise in the intensity images but causes/amplifies some anomalies of the radiative Greens function: Some cool cell just above the sharp sub-photospheric temperature drop are not heated but cool further down. Negative temperature spikes may result. This smoothing should not be used anymore.

- **character radpressure:**

In the LHDrad module there exists a simple prescription for the radiative pressure (reasonable in the optically thin) which can be activated with

```
character radpressure f=A80 b=80 n='Radiation pressure mode' &
      c0='on/off'
on
```

Allowed values are

- **on:** Radiation pressure on.
- **off:** Radiation pressure off.

The scheme is pretty slow and wrong in the optically thick. Do not use!

- **real c\_radtintminfac:**

In the LHDrad module: The fraction the interpolated temperature (at a point on the ray) may exceed the minimum temperature at its four neighbors on the HD grid can be set e.g. with

```
real c_radtintminfac f=E15.8 b=4 &
  n='Temperature interpolation parameter' u=1 &
  c0='<1.0: only bilinear, 1.1: reasonable weighting between min. und bil.'
0.0
```

The introduction of this parameter was an attempt to reduce the negative (cooling) effect of a single hot cell on its cool neighbors. It should be switched off e.g. by setting it to 0.0.

- **integer dtimestep\_out\_fine:**

This parameter can be specified but there is no corresponding output file in CO5BOLD yet.

```
integer dtimestep_out_fine f=I4 b=4 n='Output time step number'      u=1 &
  c0='dtimestep_out_fine<0 => no output'
-1
```

- **character outfile\_fine:**

The name of the file for the output of additional information at regular (small) intervals can be specified with e.g.

```
character outfile_fine f=A80 b=80 n='Output file name'
rhd.fine
```

Leaving it empty means that no file of this type is written. Specifying it means the same (yet).

- **character outform\_fine:**

The format (see Sect. 4.3.1) of the files with frequent output can be chosen e.g. with

```
character outform_fine f=A80 b=80 n='Output file format' &
  c0='formatted/unformatted'
unformatted
```

Allowed values are

- **unformatted:** (default) fast compact (possibly machine-dependent) output: strongly recommended
- **formatted:** slow (machine-independent) output, big files

This parameter can be specified but there is no corresponding output file in CO5BOLD yet.

- **character outconv\_fine:**

The conversion type (see Sect. 4.3.1) of the files with frequent output can be specified e.g. with

```
character outconv_fine f=A80 b=80 n='Output file conversion' &
  c0='ieee_4/ieee_8/crayxmp_8/native'
ieee_4
```

The allowed values depend on the machine. Leaving this field empty means that the default is chosen that is build into the local UIO module. If the type `ieee_4` is supported (which is always the case, so far) it should be chosen. This parameter can be specified but there is no corresponding output file in CO5BOLD yet.

## 5.4 Additional Control and Status Files: `rhds.stop`, `rhds.cont`, and `rhds.done`

Before each time step CO5BOLD checks in the working directory whether the file `rhds.stop` exists. If it has been generated (e.g. with `touch rhds.stop`), the code exits gracefully, i.e. it produces a proper final model, which can be used to restart the code. This method of stopping a simulation is to be preferred over a simple `kill` or `qdel` command because it allows to analyze the state of the model just at the end of the simulation and a smooth restart.

Before the restart the `rhds.stop` file has to be deleted! The simulation can be continued by just initiating a new run. If the file `rhds.cont` exists at the beginning of a simulation, the code tries to resume an interrupted computation: The initial model will not be taken from the start model file (`infile_start`) but from the final model (`outfile_end`). The data for the full and the mean file is not written into new files but will be appended to the existing ones.

In this way a simulation can be interrupted and continued in a fairly safe way. It is possible to analyze the final model and to change values in the parameter file. Keep in mind that after a restart with `rhds.cont` the specifications about the length of the job (e.g. the number of time steps) will be counted from the restart point and not from the beginning of the original simulation.

To interrupt a job with `rhds.stop` can be very handy. The continuation with `rhds.cont` and the old parameter file is not to be preferred over an ordinary restart with a new parameter file.

If a run was successful i.e. it was completed because one of the regular termination conditions was fulfilled (e.g. the requested number of time steps was performed) the exit status file `rhds.done` is produced. Currently, it contains the date and time of its generation. The existence of this file can be checked within a script to determine if the simulation was successful (and should be continued). Note: the existence of an `rhds.end` file only indicates that CO5BOLD managed to exit gracefully – due to an error or in a regular way.

## 5.5 Text Output: `rhds.out`

During execution – especially during the initialization phase – CO5BOLD writes lots of information to standard output:

After the header it starts with a block “Compiler call”, e.g.

```
pgf90 -byteswapio -fast -Mvect=sse -Mcache_align -Minfo=inline -Minline=rhd_hyd_a
vg,rhd_hyd_upwind,rhd_hyd_pred0,rhd_hyd_predm,rhd_hyd_predp,rhd_hyd_alpha,rhd_h
yd_constanteq,rhd_hyd_minmodeq,rhd_hyd_minmod,rhd_hyd_vanleereq,rhd_hyd_vanleer
,rhd_hyd_superbeeeq,rhd_hyd_superbee,rhd_hyd_ppeq,rhd_hyd_pp,rhd_hyd_hdflux,rhd
_hyd_entropyfix -Minline=rhd_rad3d_raylhd,rhd_rad3d_solve,rhd_rad3d_solveeq,rhd
_shorthead_operator,rhd_shorthead_dtauop -Drhd_hyd_roe1d_l01=0 -Drhd_r02 -Drhd_r0
3 -DMSrad_raytas1 -Drhd_hyd_entropyfix_p01=1 -Drhd_roe1d_step_t01 -Drhd_roe1d_f
lux_t01 -Drhd_vis_t01 -Drhd_bound_t01 -Drhd_shorthead_step_t01 -Drhd_shorthead_fo
rmal_t01 -Drhd_shorthead_lambda_t01
```

These lines were produced by the configure script (see Sect. 3.6) and written into the file

```
compiler_flags.info
```

which is accessed from `rhds.F90` via `include` during compilation.

Various modules now have a routine “`XXX_switchinfo`” that prints the values of the compiler switches used during the compilation of that particular module. The output can look e.g. like

```
Compiler switches: rhd_hyd_module .....
IDF:                0
rhd_hyd_gravcorr_p01: 5
rhd_hyd_entropyfix_p01: 1
rhd_hyd_upwind_p01:  0
rhd_hyd_roe1d_l01:   0
rhd_roe1d_step_l01:  0
rhd_roe1d_slope_l01: 0
rhd_roe1d_flux_l01:  undefined
```

```

rhd_bound_t01:          defined
rhd_roe1d_flux_t01:    defined
rhd_roe1d_step_t01:    defined

```

See Sect. 3.7 for more information about the meaning of the values.

The reading of the parameter file starts with

```
ACTION: Read parameter file <<<<<<<<
```

After a parameter is read, its value is printed (see Sect. 5.3)

The line

```
ACTION: Load EOS data <<<<<<<<
```

indicates the start of the reading of the equation of state data. It is followed by some information about the EOS table in use.

Similarly, the line

```
ACTION: Load opacity tables <<<<<<<<
```

indicates the start of the reading of the opacity data. The information that follows is taken directly from the header of the opacity table.

Currently, the last file to be read is the start model, which is announced by

```
ACTION: Read start model <<<<<<<<
```

and followed by some information about the start model, e.g. the number of grid points and a new section showing the quantities actually read, e.g.

Properties of start model:

time	"time"	[s]	
xc1	"x1 coordinates of cell centers"	[cm]	
xc2	"x2 coordinates of cell centers"	[cm]	
xc3	"x3 coordinates of cell centers"	[cm]	
xb1	"x1 coordinates of cell boundaries"	[cm]	
xb2	"x2 coordinates of cell boundaries"	[cm]	
xb3	"x3 coordinates of cell boundaries"	[cm]	
rho	"Density"	[g/cm <sup>3</sup> ]	
ei	"Internal energy"	[erg/g]	
v1	"Velocity 1"	[cm/s]	
v2	"Velocity 2"	[cm/s]	
v3	"Velocity 3"	[cm/s]	
quc001	"Number density of CO"	[1/cm <sup>3</sup> ]	advect(1)
bb1	"Magnetic field 1"	[G]	
bb2	"Magnetic field 2"	[G]	
bb3	"Magnetic field 3"	[G]	

It might follow

```
ACTION: Initialize MS radiation transport routines <<<<<<<<
```

And finally

```
ACTION: Open output files <<<<<<<<
```

which indicates that the `rhd.full` file (see Sect 5.1)) and the `rhd.mean` file (see Sect 5.2)) have been opened and now contain a header.

The end of the initialization phase and the beginning of the proper simulation is marked by e.g.

```
===== Start Computation =====
=== Time step number: itime= 47050 time= 2.5821813E+08 t_job= 8.510000E+00 ===
```

The output for a typical simulation time step can look like (for a supergiant model with SHORTrad radiation transport)

```
--- Time step number: itime= 49048 time= 2.6822680E+08 t_job= 1.272180E+06 ---
dttime= 5.3047E+03 HD= 1.4838E+04 RAD= 5.3047E+03 VIS= 1.0723E+05
Luminosity per core volume: 4.49999049E-02
HYD 1: N_cellsperchunk, n_chunks: 10000 1410
HYD 2: N_cellsperchunk, n_chunks: 10000 1410
HYD 3: N_cellsperchunk, n_chunks: 10000 1410
VIS3D: N_cellsperchunk, n_chunks: 10000 1360

=== Start of rhd_shorttrad_step ===
n_subdttime: 1
minmax(T) 1.111651E+03 1.630733E+05
Main ( 1/ 3) ray direction 2: 0.000000 1.000000 0.000000 -----
Main ( 2/ 3) ray direction 3: 0.707105 0.000000 0.707109 -----
Main ( 3/ 3) ray direction 3: -0.707105 0.000000 0.707109 -----
Time step ratio: dttime/dttime_rad: 1.750409E+01
dttime_:rad,drhoei,limit_this,all: 6.667E+02 2.510E+03 6.276E+02 0.000E+00
n_subdttime: 2
minmax(T) 1.116348E+03 1.630658E+05
Main ( 1/ 3) ray direction 1: 1.000000 0.000000 0.000000 -----
Main ( 2/ 3) ray direction 3: 0.000000 0.707105 0.707109 -----
Main ( 3/ 3) ray direction 3: 0.000000 -0.707105 0.707109 -----
Time step ratio: dttime/dttime_rad: 1.836970E+01
dttime_:rad,drhoei,limit_this,all: 6.353E+02 3.188E+03 7.971E+02 6.276E+02
...
n_subdttime: 8
minmax(T) 1.118540E+03 1.630164E+05
Main ( 1/ 3) ray direction 2: -0.707105 0.707109 0.000000 -----
Main ( 2/ 3) ray direction 2: 0.707105 0.707109 0.000000 -----
Main ( 3/ 3) ray direction 3: 0.000000 0.000000 1.000000 -----
Time step ratio: dttime/dttime_rad: 1.791384E+01
dttime_:rad,drhoei,limit_this,all: 6.515E+02 3.894E+03 8.884E+02 4.814E+03
=== End of rhd_shorttrad_step =====
```

A simulation ends with e.g.

```
=== Time step number: itime= 49050 time= 2.6823742E+08 t_job= 1.273407E+06 ===
===== End Computation =====
```

A proper exit is indicated by

```
-----
Exit information: Requested number of time steps done
Exit status: 0
-----
```

In this case a file `rhd.done` (see Sect. 5.4) is produced. A messages like

```
*****
Severe error: SHORTRAD: Time step below absolute limit
Error index: 100
Interrupt computation
*****
```

marks an exit with an error and without `rhd.done` file. A message about the final model like

ACTION: Write final model <<<<<<<<  
 Model file 'rhd.end' opened on channel 12

is followed by some timing information like e.g.

Timing statistics (rate x factor= 1000000 x 10000)

Process	Samples	Total time [sec]	Mean time [sec]
RHD code	1	410.830017	410.830017
uio output routines	27	37.469997	1.387778
HYD: bound_3Dcenter	2000	3.540000	0.001770
Hydrodynamics routines	2000	48944.660156	24.472330
HYD: 1	2000	16350.610352	8.175305
HYD: 2	2000	16052.459961	8.026230
HYD: 3	2000	16520.798828	8.260400
Viscosity routines 3D	2000	25446.400391	12.723200
VIS: make_box(modelvis)	2000	0.010000	0.000005
VIS: copy_box(modelvis)	2000	1750.960083	0.875480
VIS: delete_box(modelvis)	2000	0.000000	0.000000
Radiation transport routines	2000	243729.000000	121.864502
SHC: step	2020	244064.515625	120.824020
SHC: step: dtime: init: EOS	16024	49312.738281	3.077430
SHC: step: dtime: explicit	16024	174542.343750	10.892558
SHC: formal	16024	170085.437500	10.614418
SHC: formal: init	16024	35591.378906	2.221129
SHC: formal: dirloop	16024	133010.687500	8.300717
SHC: formal: exp	28014	9014.280273	0.321778
SHC: formal: exp: expl2t	28014	3950.409912	0.141016
SHC: formal: dir3	36083	63222.242188	1.752134
SHC: time: dir3	36083	19676.009766	0.545299
SHC: formal: limitei	16024	1306.419922	0.081529
SHC: step: dtime: final	16024	12730.129883	0.794441
SHC: formal: dir2	11959	22205.000000	1.856761
SHC: time: dir2	11959	5731.149902	0.479233
SHC: formal: dir1	4044	10674.429688	2.639572
SHC: time: dir1	4044	1893.760010	0.468289
SHC: step: dtime: final(output)	181	8620.870117	47.629116
Radiation trans.: output only	20	335.929993	16.796499

In this example the value for the overall time ("rhd code 410.830017 sec") is not useful because of an overflow in the counter. However, it is evident that the radiation transport consumes most of the time (243729.000000 sec), followed by the hydrodynamics routines (48944.660156 sec) and the tensor viscosity routines (25446.400391 sec). Some of these values are split further.



## 6 Running a Simulation

### 6.1 Quickstart: How to Run CO5BOLD

The generation of a start file and the modification of the parameter file is a somewhat complex process. In short, the following steps have to be performed.

1. Produce an executable `rhd.exe` (see Sect. 3.1) and put it into your working directory.
2. Choose a start model (e.g. the final model of an earlier simulation or a model produced with an IDL routine).
3. Edit the parameter file `rhd.par`: typically, you will start with an existing file and edit it. You should check that the paths and names of EOS, opacity, and start file are set correctly (Watch the username!). For details about the parameter file see Sect. 5.3.1.
4. Start the simulation with  

```
nice nohup rhd.exe > rhd.out &
```
5. You can see how the simulation proceeds with  

```
tail -f rhd.out
```
6. The other data files usually are in a binary format (this can be changed to ASCII “formatted” in `rhd.par`). Their contents can be read and analyzed with IDL routines (see Sect. 4.7.3).

For machines with batch queue (CRAYs in Kiel, SUN1 in Uppsala) there is a script, which can handle an entire sequence of simulations (see Sect. 6.2).

## 6.2 Running CO5BOLD on a Machine with Batch System

For longer simulations it is inconvenient to restart the individual jobs by hand. This task is done by a script originally from Hans-Günter Ludwig. Its basic function is sketched in Fig. 3.

### CO5BOLD - function diagram

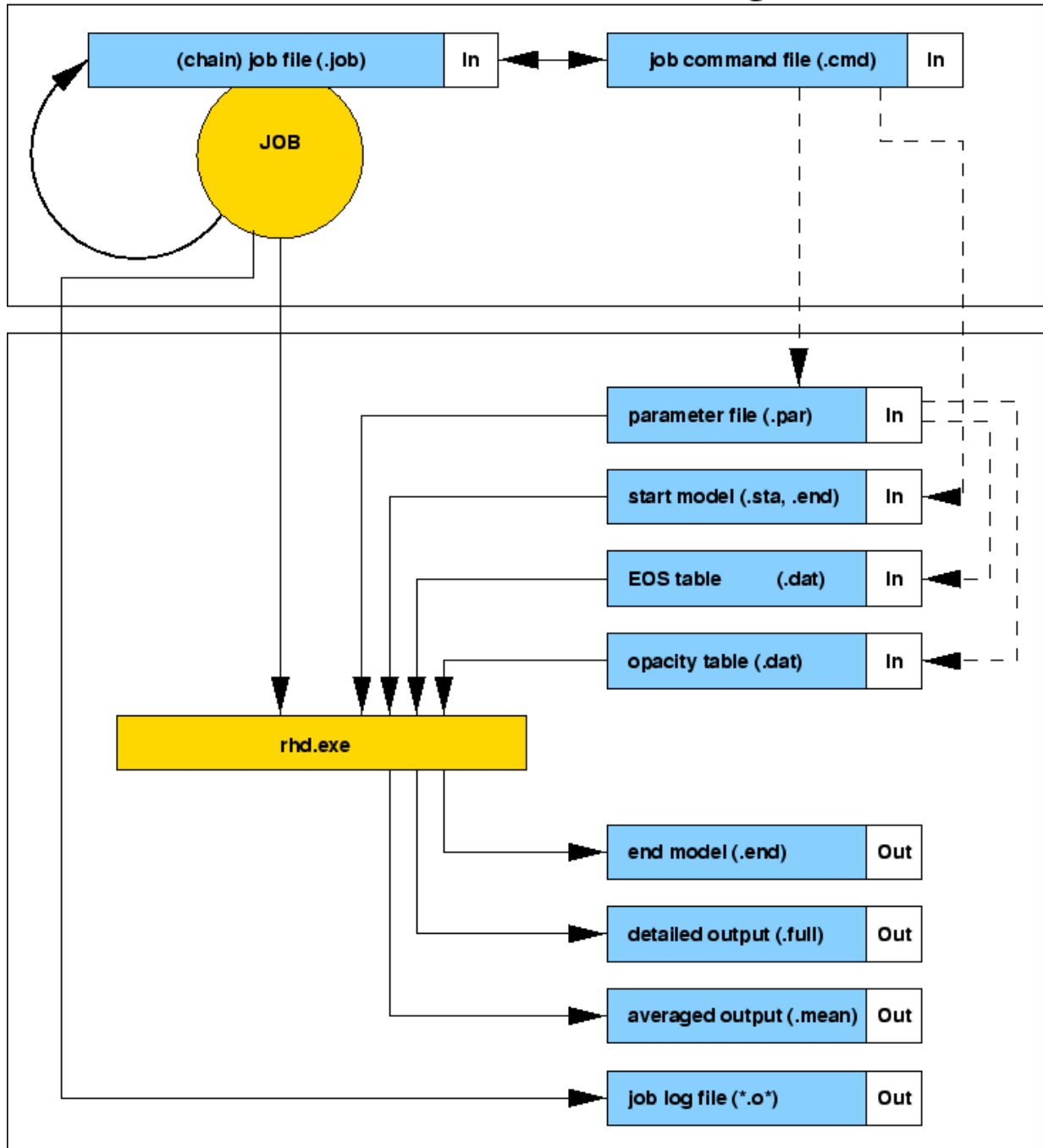

Figure 3: Program scheme

Here comes an example of the script (`rhdl.job`) for a system without dedicated batch system. The submission of a job is done via `nohup rhdl.job`:

```
#!/bin/sh
#--- PBS -N rhdl
#--- PBS -l walltime=72:00:00
#--- PBS -l nodes=1:ppn=4
#
# --- Job file for the execution of RHD on gunnar (Itanium 2, Uppsala) ---
# --- Source: rhdl.job, original from HGL ---
```

```

# --- Last modification: 2002-12-13          ---
#
#set -xv
#
BASEDIR=/users/bf/dat/job/j1
STADIR=${BASEDIR}/sta      # Start directory: contains *.par, rhd1.cmd, rhd1.job
WRKDIR=${BASEDIR}/wrk     # Work directory
BAKDIR=${BASEDIR}/bak     # Backup and output directory
RHDEXE=${STADIR}/rhd.exe  # RHD program to be executed
#
#export NCPUS=4
#echo $NCPUS
export OMP_NUM_THREADS=1
#
# --- Jump into work directory ---
cd $WRKDIR
#
# --- Loop: execute RHD code (possibly) several times in one job -----
for IRUN in 1
do
  echo
  echo 'CO5BOLD Run #' $IRUN
  date
  #
  # --- Clear up work directory ---
  #set +e
  rm *
  #set -e
  #
  #####
  #
  # --- Get old command file, select actual command line ---
  # --- and read variables from command line          ---
  #
  cp -p $STADIR/rhd1.cmd rhd1.cmd
  #
  awk \
  '
    /#/ { print; next}
    /\*/ { print; next}
    /\+ / { print; next}
    DONE!="T" { print >"cmdline"; printf "%-77s*\n", $0; DONE="T"; next}
    { print} ' rhd1.cmd | cat > dummy_nrhd.cmd

  #
  read INFILE OUTFILE PARFILE ACT < cmdline
  mv dummy_nrhd.cmd ${OUTFILE}_nrhd.cmd
  echo ${INFILE}
  echo ${OUTFILE}
  echo ${PARFILE}
  echo ${ACT}
  #
  #####
  #
  if [ "${ACT}" != dum ]
  then
    #####
    #
    # --- RHD execution ---
    #
    # --- Copy parameter file ---
    cp -p ${STADIR}/${PARFILE} rhd.par
    #

```

```

# --- Copy start file ---
if test -s ${BAKDIR}/${INFILE}
then
  cp -p ${BAKDIR}/${INFILE} rhd.sta
else
  cp -p ${STADIR}/${INFILE} rhd.sta
  cp -p rhd.sta ${BAKDIR}/${INFILE}
fi
# --- Copy executable ---
cp -p ${RHDEXE} rhd.exe
#
# --- Execute RHD ---
./rhd.exe > rhd.out
RHD_EXIT=$?
#
if [ "$RHD_EXIT" != 0 ] || [ ! -s rhd.done ]
then
  # --- Exit status not zero, ---
  # --- error may have occurred during execution of rhd.exe ---
  if [ "$RHD_EXIT" != 0 ]
  then
    echo 'Non-zero exit status ' $RHD_EXIT ' occurred during execution of RHD!'
  else
    echo 'No rhd.done file found: assume error during execution of RHD!'
  fi
  echo 'Execution of job chain terminated!'
  # --- Modify nrhd.cmd, set termination character "+" ---
  awk \
  '
    /#/    { print; next}
    /\*/    { print; next}
    /\+/    { print; next}
    DONE!="T" { printf "%-77s+\n", $0; DONE="T"; next}
              { print} ' rhd1.cmd | cat > nrhd.cmd
  # --- Terminate chain by simulating ${ACT} = eoc ... ---
  ACT=eoc
else
  # --- Modify command file: add '*' in appropriate column to indicate ---
  # --- proper execution ---
  awk \
  '
    /#/    { print; next}
    /\*/    { print; next}
    /\+/    { print; next}
    DONE!="T" { print >"cmdline"; printf "%-77s*\n", $0; DONE="T"; next}
              { print} ' rhd1.cmd | cat > nrhd.cmd
fi
#
ls -l
#
# --- Move data into backup directory ---
cp -p rhd.par  ${BAKDIR}/${PARFILE}
mv rhd.out  ${BAKDIR}/${OUTFILE}.out
mv rhd.par  ${BAKDIR}/${OUTFILE}.par
#mv rhd.sta  ${BAKDIR}/${OUTFILE}.sta
mv rhd.end  ${BAKDIR}/${OUTFILE}.end
mv rhd.full ${BAKDIR}/${OUTFILE}.full
mv rhd.mean ${BAKDIR}/${OUTFILE}.mean
chmod go+r ${BAKDIR}/${PARFILE} ${BAKDIR}/${OUTFILE}.*
chmod go-w ${BAKDIR}/${PARFILE} ${BAKDIR}/${OUTFILE}.*
#
#####
fi

```

```

#
#
#####
#
# --- Dispose modified command file for next job ---
cp -p nrhd.cmd $STADIR/rhd1.cmd
#
# --- Exit loop if end of chain reached ---
if test ${ACT} = eoc
then
    break
fi
#
# --- End of loop -----
done
#
# --- Submit next job if not end of chain reached---
if test ${ACT} != eoc
then
    cd $STADIR
    echo "Resubmit job"
# /usr/local/bin/qsub rhd1.job
# qsub rhd1.job
# nice nohup rhd1.job &
    nohup rhd1.job &
else
    echo "End of job chain"
fi
#
#####

```

Basic informations about the batch system of the Ångström Sun cluster<sup>10</sup> are available.

A more detailed description of the script will come sometimes in the future (e.g. from Sven's manual...).

---

<sup>10</sup><http://www.fysik4.fysik.uu.se/sunkluster/>

## 7 Data Analysis with IDL

In this section some basic commands for handling CO5BOLD data in IDL are described. See also Sect. 4.7

**NOTE:** Before using IDL the environment variables for the CO5BOLD paths should have been set. Use `setarcdeppaths.sh` (or `.ksh`, `.csh`) for this purpose. Important is `UIOPATH` which specifies where to find the IDL routines for the UIO handling.

### 7.1 Preparations

We recommend to create an initialisation file (e.g. named `start.pro`) which should be called after starting IDL (e.g. `@start`). This is necessary to define relevant paths of IDL subroutines and to provide the UIO package. Thus, the file should contain the following:

```
; --- Add user IDL directory to search path ---
addpath=expand_path('+${UIOPATH}/idl')
addpath=addpath+':'+expand_path('+$HOME/HYDRO/IDL/rhdpro')
if strtrim(addpath,2) ne '' then !path=addpath+':'+!path
delvar, addpath
; --- Initialize uio-routines ---
uio_init, progrm='by hand'
```

Alternatively, one might want to set the IDL path variable accordingly like

```
export IDL_PATH="+${UIOPATH}/idl"
```

for example in the `.bashrc` file.

### 7.2 CO5BOLD Data in IDL

Important to know is that all operations can be performed in the command line of IDL. This allows an interactive processing of CO5BOLD data. Moreover, there are already prepared IDL scripts for this purpose but most of them are rather complex and still have to be edited (e.g. changing file names). For the beginning it is more clear to use single commands. We give a short overview of some essential commands.

#### 7.2.1 Loading the Parameter File

```
IDL> parfile='mymodel.par'
IDL> par=uio_struct_rd(parfile)
```

All control parameters are provided in the structure `PAR`.

#### 7.2.2 Loading CO5BOLD Data (.full, .sta, .end)

```
IDL> modelfile='/home/user/mymodel.full' & n=0
IDL> ful=uio_dataset_rd(modelfile,n=n)
```

First the name and full path (if not in the actual directory) of the model file and the wanted time step should be defined. Here, time step means the consecutive number of the model snapshot in the file. Declaring a time step number greater than the number of snapshots contained in the file will cause an error.

Otherwise all data of the particular time step `n` will be provided in the structure `FUL`. Loading more than one timestep from the same file could be achieved as follows:

```
IDL> uio_openrd, nc, modelfile, outstr, ierr
```

```
IDL> for i=0,ntime-1 do begin &$
IDL>   ful=uiodataset_rd(modelfile, channel=nc,ierr=ierr, outstr=err_msg) &$
IDL> endfor &$
IDL> uioclosrd, nc
```

Again, this operation would cause an error if the wanted time step is not contained in the file. Via checking the error flag `ierr` of the routine `uiodataset_rd` such errors can be avoided. This way it is unnecessary to know exactly of how many time steps the model file consists.

```
IDL> uiopenrd, nc, modelfile, outstr, ierr
IDL> i=0
IDL> repeat begin &$
IDL>   ful=uiodataset_rd(modelfile, channel=nc,ierr=ierr, outstr=err_msg) &$
IDL>   if (ierr eq 0) then begin &$
IDL>     ;--- hier Daten bearbeiten oder in anderer Variable speichern ---
IDL>     i=i+1 &$
IDL>   endif else begin &$
IDL>     print,'IDL> Reached EOF.' &$
IDL>   endelse &$
IDL> endrep until (ierr ne 0) or (EOF(nc))
IDL> uioclosrd, nc
```

To read a number of entries from a list of files in sequence the routine `uiodatasetlist_rd.pro` (see Sect. 4.7.3) is appropriate.

### 7.2.3 Loading the Equation of State

```
IDL> eosfile='../eos/dat/'+par.eosfile
IDL> tabinter_rdcoeff,eosfile, eos
```

The table for the equation of state is provided in the structure `EOS`.

**NOTE: Always check file name and path!**

### 7.2.4 Loading the Opacity Table

```
IDL> opafile='../opa/dat/'+par.opafile
IDL> dfopta,opafile
```

The opacity table will be stored as common block `OPTA_COMMON`.

**NOTE: Always check file name and path!**

### 7.2.5 Computation of Deduced Quantities

After having read the model data (`FUL`) and the tables for the equation of state (`EOS`) and opacity (`OPTA_COMMON`) (see 7.2.3, 7.2.4), more quantities can be calculated:

```
IDL> eosbox, ful, eos=eos, /opa, ierror=ierror
```

This operation adds the tags `EOS` and `OPA` to the data structure `FUL` which contain more quantities like e.g. the temperature (see Sect.7.3).

## 7.3 IDL Data Structure

The data structure `FUL` contains the following variables and substructures. Use `help,/str,ful`, to get this information. See also the short description of the contents of a model file in Sect. 5.1 and particularly the man-page of the script `uiolook` in Sect. 4.6.1 which gives you even more detailed information directly from the file:

```

** Structure <8287a0c>, 9 tags, length=78404128, refs=1:
  TYPE          STRING      'uio'
  HEAD          STRUCT      -> <Anonymous> Array[1]
  DATASET_ID    STRING      'single_box'
  MODELTIME     FLOAT        10050.1
  MODELITIME    LONG         64088
  DTIME         FLOAT        0.176381
  TIME_OUT_FULL_LAST FLOAT    10050.1
  TIME_OUT_MEAN_LAST FLOAT    10040.0
  Z             STRUCT      -> <Anonymous> Array[1]

```

If the command in Sect.7.2.5 has been performed, the following substructures are present:

```

EOS          STRUCT      -> <Anonymous> Array[1]
OPA          STRUCT      -> <Anonymous> Array[1]

```

The substructure `FUL.Z` contains the original data arrays from the model file like the spatial axes, density `rho`, internal energy `ei`, and the three spatial components of the velocity (`v1`, `v2`, `v3`):

```

** Structure <8274184>, 16 tags, length=78403900, refs=2:
  TYPE          STRING      'uio'
  BOX_ID        STRING      'z'
  DIMENSION     LONG         Array[2, 3]
  TIME          FLOAT        10050.1
  ITIME         LONG         64088
  XC1           FLOAT        Array[140, 1 , 1 ]
  XC2           FLOAT        Array[1 , 140, 1 ]
  XC3           FLOAT        Array[1 , 1 , 200]
  XB1           FLOAT        Array[141, 1 , 1 ]
  XB2           FLOAT        Array[1 , 141, 1 ]
  XB3           FLOAT        Array[1 , 1 , 201]
  RHO           FLOAT        Array[140, 140, 200]
  EI            FLOAT        Array[140, 140, 200]
  V1            FLOAT        Array[140, 140, 200]
  V2            FLOAT        Array[140, 140, 200]
  V3            FLOAT        Array[140, 140, 200]

```

Spatial axes: `XC1`, `XC2`, `XC3`, `XB1`, `XB2`, `XB3`:

The indices stand for 1:x, 2:y, 3:z. `C` for the grid cell centre, `B` for the boundaries. Most of the quantities are defined for the cell centres. In case of doubt, this can be found out by checking the array dimensions.

The substructure `FUL.EOS` contains important quantities like the temperature `T`, gas pressure `P`, entropy `S`:

```

** Structure <826a03c>, 6 tags, length=109760000, refs=2:
  P             FLOAT        Array[140, 140, 200]
  DPDRHO       FLOAT        Array[140, 140, 200]
  DPDEI        FLOAT        Array[140, 140, 200]
  T            FLOAT        Array[140, 140, 200]
  DTDEI        FLOAT        Array[140, 140, 200]
  S            FLOAT        Array[140, 140, 200]

```

The substructure `FUL.OPA` only contains the opacity `KAPPA`:

```

** Structure <826a5b4>, 1 tags, length=15680000, refs=2:
  KAPPA        FLOAT        Array[140, 140, 200]

```



## 7.4 More IDL routines

In the directory `IDL/rhdpro` a lot of useful routines can be found which can be used for further processing and visualisation of CO5BOLD data. For the visualisation of 2-D models or 2-D data slices in general we recommend `plotfield.pro`. With `combox.pro` (unfortunately not commented yet) further quantities can be calculated.

Furthermore, we currently develop a widget-based analysis tool called **COBOLD AT** (abbrev.: CAT) which will help to work with CO5BOLD data without having to write and edit own IDL code. The routines are stored (if available) in the directory `IDL/COBOLDAT` and have to be started with `@cat`. A more detailed documentation is planned.

## 8 Glossary

- **CO5BOLD** or **COBOLD** is the short form of “COnservative COde for the COmputation of COmpressible COnvection in a BOx of L Dimensions with l=2,3”.
- **EOS**: “Equation Of State”
- **RHD**: “Radiation HydroDynamics”
- **UIO**: the “Universal Input Output” format. It is used in CO5BOLD for parameter, model, mean, and EOS files.

# Index

- alpha, 27
- batch queue, 90
- big\_endian, 31–33, 39, 42
- boundary conditions, 61
- chemical composition, 64
- CO5BOLD, 5, 98
- compilation, 7–36
- compiler
  - alpha, 27
  - Cray, 27
  - Hewlett-Packard, 27, 28
  - Hitachi SR8000, 29
  - Intel, 32
  - NEC SX-5, 33
  - PGI, 31
  - SGI, 33
    - UKAFF, 34
  - Sun, 34
- compiler macro, 18–26
  - category, 18
  - gasinter\_l01, 19
  - IDF, 20
  - MSrad\_raytas, 26
  - rhd\_shortrad\_lambda\_l01, 26
  - rhd\_bound\_t01, 22
  - rhd\_box\_bmag01, 20
  - rhd\_box\_grav01, 19
  - rhd\_box\_quc01, 19
  - rhd\_hyd\_entropyfix\_p01, 21
  - rhd\_hyd\_gravcorr\_p01, 21
  - rhd\_hyd\_roe1d\_l01, 21
  - rhd\_hyd\_upwind\_p01, 21
  - rhd\_r01, 22
  - rhd\_r02, 23
  - rhd\_r03, 23
  - rhd\_rad3d\_dir\_t01, 24
  - rhd\_rad3d\_fromray\_l01, 23
  - rhd\_rad3d\_r02, 23
  - rhd\_rad3d\_solve\_t01, 23
  - rhd\_rad3d\_step\_t01, 24
  - rhd\_rad3d\_toray\_l01, 23
  - rhd\_roe1d\_flux\_l01, 21
  - rhd\_roe1d\_flux\_t01, 22
  - rhd\_roe1d\_slope\_l01, 20
  - rhd\_roe1d\_step\_t01, 22
  - rhd\_shortrad\_dir1\_l01, 25
  - rhd\_shortrad\_dir\_l02, 25
  - rhd\_shortrad\_dtauop\_l01, 25
  - rhd\_shortrad\_dtauop\_l02, 25
  - rhd\_shortrad\_formal\_l01, 25
  - rhd\_shortrad\_formal\_t01, 26
  - rhd\_shortrad\_operator\_l01, 24
  - rhd\_shortrad\_operator\_l02, 24
  - rhd\_shortrad\_step\_t01, 26
  - rhd\_vis\_density\_p01, 22
  - rhd\_vis\_t01, 22
  - timing\_c\_factor, 19
- configure script, 17–18, 85
- control variables, 17
  - F90\_BASEPATH, 18
  - F90\_COMPILER, 17
  - F90\_DEBUG, 17
  - F90\_DUST, 18
  - F90\_LHDRAD, 17
  - F90\_MACHINE, 18
  - F90\_MHD, 18
  - F90\_MS RAD, 18
  - F90\_PARALLEL, 17
  - F90\_POSTFLAGS, 17
  - F90\_PREFLAGS, 17
  - F90\_SHORTRAD, 18
- craSHi, 27
- Cray, 27, 75
- data format, 37
- dust, 5, 20, 69
- entropy fix, 21
- environment variables, 10, 12, 18
- EOS, 64
- equation of state, 64
- fluxes, 53
- formatted, 38
- Fortran, 5, 14, 37, 42
- Hewlett-Packard, 27, 28
- Hitachi, 29
- hydrodynamics, 5, 6, 65
- hydrodynamics routines, 15, 16
- IDL, 37, 94
  - UIO routines, 48
  - uio\_data, 50
  - uio\_datasetlist\_rd, 51
  - uio\_dataset\_rd, 50
  - uio\_init, 49
- inlining, 26
  - alpha, 27
  - Cray VX1, 27
  - Intel compiler on Linux, 32
  - PGI compiler on Linux, 31
  - SGI, 33

- Sun, 36
- Intel, 32
- Itanium, 28
- LHDrad, 5, 15, 16, 70
- Linux, 31, 32
- little\_endian, 31, 32, 39, 43
- magnetic fields, 5, 20
- makefile, 14
  - configure script, 17
  - UIO, 44
- MSrad, 5, 15, 16, 23, 27, 29, 31, 32, 36, 63, 70
  - cell centering, 53
- NEC SX-5, 33
- opacities, 64
- OpenMP, 5, 26, 33
  - activation in configure script, 17
  - chunk size, 67, 69
  - on Cray VX1, 27
  - on Hitachi, 29
  - on SGI, 33
  - on Sun, 36
- output
  - full data sets, 52
  - mean data, 53
  - rhd.done, 85
  - rhd.out, 85
- radiation transport, 5, 70
- README, 7
- rhd.cont, 85
- rhd.done, 85
- rhd.exe, 7, 9
- rhd.out, 85
- rhd.par, 52, 57–84
  - boundary conditions, 61
  - character bottom\_bound, 61
  - character description, 59
  - character dustscheme, 69
  - character eosfile, 64
  - character eospath, 64
  - character file\_id, 59
  - character grav\_mode, 59
  - character hdscheme, 65
  - character history, 59
  - character infile\_start, 80
  - character opafile, 64
  - character opapath, 65
  - character outconv\_end, 81
  - character outconv\_fine, 84
  - character outconv\_full, 81
  - character outconv\_mean, 82
  - character outfile\_end, 80
  - character outfile\_fine, 84
  - character outfile\_full, 80
  - character outfile\_mean, 81
  - character outform\_end, 81
  - character outform\_fine, 84
  - character outform\_full, 81
  - character outform\_mean, 82
  - character radpressure, 83
  - character radraybase, 71
  - character radraystar, 72
  - character radscheme, 70
  - character reconstruction, 66
  - character side\_bound, 61
  - character top\_bound, 61
  - dust, 69
  - effective temperature, 59, 62
  - equation of state, 64
  - fileform uio, 58
  - gravity, 59
  - header, 58
  - hydrodynamics, 65
  - input/output, 79
  - integer dtimestep\_out\_fine, 84
  - integer endtimestep, 76
  - integer n\_hydcellsperchunk, 29, 66
  - integer n\_radband, 73
  - integer n\_raditer, 71
  - integer n\_radmaxiter, 71
  - integer n\_radminiter, 71
  - integer n\_radphi, 72
  - integer n\_radsubray, 72
  - integer n\_radtaurefine, 73
  - integer n\_radtheta, 72
  - integer n\_radthickpoint, 73
  - integer n\_visccellsperchunk, 69
  - integer plustimestep, 76
  - integer starttimestep, 75
  - luminosity, 62
  - opacities, 64
  - process management, 75
  - radiation transport, 70
  - reading in IDL, 50
  - real abux, 82
  - real abuy, 82
  - real c\_radkappasmooth, 83
  - real c\_courant, 77
  - real c\_courantmax, 78
  - real c\_dust0X, 69
  - real c\_hptopfactor, 63
  - real c\_maxeichange, 78
  - real c\_pchange, 63
  - real cputime, 75
  - real cputime\_remainlimit, 75

- real c\_radcourant, 78
- real c\_radcourantmax, 78
- real c\_radhtautop, 63
- real c\_radimplicitmu, 73
- real c\_raditereps, 74
- real c\_raditerstep, 74
- real c\_radmaxeichange, 79
- real c\_radthintimefac, 79
- real c\_radtintminfac, 84
- real c\_radtsmooth, 83
- real c\_radtvis, 74
- real c\_radtvisdtau, 74
- real c\_schange, 62
- real c\_slopered, 66
- real c\_tchange, 63
- real c\_tsurf, 63
- real c\_visartificial, 68
- real c\_visbound, 67
- real c\_viscourant, 79
- real c\_viscourantmax, 79
- real c\_visdrag, 67
- real c\_visneu1, 83
- real c\_visneu2, 83
- real c\_visprturb, 68
- real c\_vissmagorinsky, 67
- real c\_vistensordiag, 68
- real c\_vistensordiv, 68
- real c\_vistensoroff, 68
- real dtime\_incmax, 77
- real dtime\_max, 77
- real dtime\_min, 77
- real dtime\_min\_stop, 77
- real dtime\_out\_full, 80
- real dtime\_out\_mean, 80
- real dtime\_start, 76
- real endtime, 76
- real gamma, 82
- real grav, 60
- real luminositypervolume, 62
- real mass\_star, 60
- real plustime, 76
- real qmol, 82
- real r0\_grav, 60
- real r1\_grav, 60
- real r1\_rad, 60
- real rho\_min, 64
- real s\_inflow, 62
- real starttime, 75
- real teff, 59
- tensor viscosity, 67
- time step, 76
- rhd.stop, 85
- Roe solver, 27, 29, 31
- SGI, 33
- short characteristics, 31
- SHORTrad, 5, 15, 16, 70
- Sun, 34
- tensor viscosity, 67
- tensor viscosity routine, 15, 16
- time step, 71
- timing statistics, 19, 88
- total energy flux, 57
- UIO, 37–51
  - conversion type, 38
  - example, 37, 39, 40
  - format, 38
  - Fortran, 42
  - IDL, 48
  - makefile, 44
  - record length unit, 27
  - uio\_mac\_module, 42
  - Unix scripts, 46
- uiocat, 47
- uio\_datasetlist\_rd, 51
- uio\_dataset\_rd, 50
- uioinfo, 47
- uio\_init, 49
- uiolook, 46
- uio\_struct\_rd, 50
- UKAFF, 34
- unformatted, 38
- xb1, 53
- xb2, 53
- xb3, 53
- xc1, 53
- xc2, 53
- xc3, 53